

Received: 2005.06.07
Accepted: 2006.02.28
Published: 2006.04.28

Authors' Contribution:

- A** Study Design
- B** Data Collection
- C** Statistical Analysis
- D** Data Interpretation
- E** Manuscript Preparation
- F** Literature Search
- G** Funds Collection

Dynamic wedges – dosimetry and quality control

Krzysztof Chełmiński^{A,G,F}, Wojciech Bulski^{A,E,G}, Joanna Rostkowska^{A,B,D},
 Małgorzata Kania^{B,D}

Maria Skłodowska-Curie Oncology Centre, Warsaw

Source of support: Financed by a KBN grant, number: 6P05B 06721 (2001–2004)

Summary

Background

Modern medical accelerators are usually equipped with a dynamic wedge option. It is a form of dose-rate modulation which makes use of the dynamic movement pairs of collimator jaws. Dynamic wedges may replace physical wedges but their use requires more complex dosimetry and quality control procedures. Film dosimetry has been proposed as a quality control tool in dynamic dose distribution. We present examples of extensive systematic calculation errors which were detected during complex dosimetry quality control procedures in two treatment planning systems.

Aim

The aim, in presenting QA procedures and examples of systematic errors which were detected and corrected, is to focus attention on the QA of dynamic accessories used in TPS before they are used in the clinical practice. This is an important issue which may have been frequently overlooked as the configuration of dynamic wedges in many treatment planning systems requires no dose measurement data. Measurements of verifications are often, overlooked.

Materials/Methods

Dynamic wedge dose distributions were generated by Clinac 2300 C/D accelerators (Varian) for beam energies of 6 and 15MV. Measurements were performed with LA48 linear array of ionization chambers (PTW), and with dosimetric films X-Omat V and EDR-2 (Kodak). The dosimetric characteristics of the film were examined for a wide range of dose values and beam parameters. The results of the measurements were compared with dose distribution calculations produced by the treatment planning systems Helax and CadPlan/Eclipse.

Results

The initial results showed considerable differences between measurements and calculations. Larger differences were observed for larger wedge angles and lower energies. On the basis of these results, TPS manufacturers were able to tune their calculation algorithms which effectively reduced the observed differences from a level of -5.5% and -8% (for 15 and 6MV respectively) for 60° wedges to a level of $\pm 2\%$ for the Helax system.

Conclusions

A comprehensive quality control procedure for a broad range of dynamic wedge parameters, on a Clinac 2300C/D, made it possible to achieve an improved agreement between measured and calculated results in radiotherapy. Such measurement procedures should be included in the recommendations for periodic quality control tests of accelerators.

Key words

EDW • dynamic wedge • treatment planning systems • film dosimetry

Full-text PDF: <http://www.rpor.pl/pdf.php?MAN=8862>

Word count: 1830

Tables: 4

Figures: 16

References: 29

Author's address: Wojciech Bulski, Department of Medical Physics, Maria Skłodowska-Curie Oncology Centre, Roentgena 5 Str., 02-781 Warsaw, Poland

BACKGROUND

A method, proposed by Kijewski et al. In 1978 [5], to use computer controlled dynamic movement of the collimator jaws to simulate physical wedges in the shaping of dose distribution was implemented in Varian Clinac accelerators. The first implementation of Dynamic Wedges (DW) provided four wedge angles of 15, 30, 45, and 60 degrees [6,7]. The DW option was programmed on the basis of 256 Segmented Treatment Tables (SST) providing continuous outputs as a function of jaw positions for all beam energies of symmetrical fields of range 4–20cm [8].

Both groups, Kijewski et al. [5] and Leavitt et al. [6], performed measurement dose distributions for dynamic wedges with dosimetry films because they could not be done in the conventional manner, using an ionization chamber in a water phantom [9]. In 1992, Leavitt and Larsson tested a method for dynamic wedge measurements using a line of 11 semiconductor detectors [10]. In 1994, Bidmead et al. used a line of semiconductor detectors (Scanditronics LDA/11) to measure a series of DW profiles. The results were used to generate basic data for treatment planning systems (TPS) which was similar to the data for physical wedges [11].

The following version of dynamic wedges, known as Enhanced Dynamic Wedges (EDW), was installed in Varian Clinac accelerators from 1995 and provided an asymmetric wedged fields option. This provided standard wedge angles of 10, 15, 20, 25, 30, 45, and 60 degrees, as well as any angle in the range 0–60 degrees. In the EDW option only the Golden STT table for 60 degree wedges is required [7,12]. EDW wedge angles in the range of 0–60 degrees were generated by superimposition of an open field and an EDW 60 degree field in appropriate proportions, as in the physical wedge system, Philips Universal Wedge [13].

Numerous authors [14–16] have confirmed the possibility of using the Golden STT table in

treatment planning system calculation algorithms for EDW fields, on the basis of profile data for open fields. Initially, this option was implemented only in some TPS [17–20]. In other systems the EDW calculations were performed as for physical wedges, on the basis of empirical output tables [21], or in a hybrid manner, using data from Golden STT tables [22–24].

AIM

The aim of this paper was the dosimetric verification of EDW calculation algorithms implemented in the Helax and CadPlan treatment planning systems [1–4].

MATERIALS AND METHODS

Dosimetry measurements were performed for Varian Clinac 2300 C/D accelerators, equipped with the EDW option for 6 and 15 MV photon beams.

The EDW option provides 7 wedge angle values: 10, 15, 20, 25, 30, 45, and 60 degrees. The dynamic wedge is realized by continuous movement of one collimator jaw, gradually reducing the field size until the collimator is almost completely closed, while the beam is on. The overall wedge field size is defined by the initial collimator setting. In the Varian implementation the dynamic wedge angle is defined differently than it is for physical wedge angles [7,25], Figure 1 [26] and Figure 2 [27].

The wedge field profiles were measured using LA-48 linear array of ionization chambers from PTW in MP-3 ware phantom (both from PTW-Freiburg) and a 0.6ccm NE-2571 ionization chamber. The LA-48 array is composed of 48 ionization chambers at 8mm intervals. The computer software of the Mefysto system (PTW) positions the array in the MP3 phantom and makes it possible to measure the profile doses at 2mm intervals. The array had to be irradiated four times with the same field. The beam profile was measured

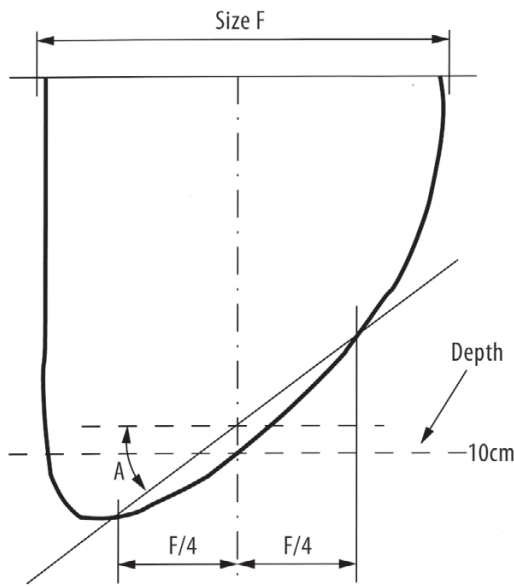

Figure 1. Enhanced Dynamic Wedge definitions, as recommended by the ICRU and IEC. A – wedge angle.

at a depth of 10cm in water, perpendicularly to the beam axis and parallelly to the direction of the jaw movement, using an asymmetric field size of 30×10cm. Such an asymmetric EDW field may be realised by the displacement of one of the collimator jaws from the position $Y1=20\text{cm}$ to the position $Y1=-10\text{cm}$, on the opposite side of the beam axis, while the beam is on. Such a field size, at the maximum available length, modified by the 60 degree EDW, made it possible to achieve the maximum range of dose values for the profile of a single beam. For each field the dose value on the beam axis was measured using an ionization chamber at a depth of 10cm. Such profiles, measured for 6 and 15MV beams, were used to establish the characteristics of Kodak X-Omat V and EDR2 films [28]. These films were then used for the measurement of dose distributions in wedged fields. The films were placed at 10cm depth, perpendicularly to the beam axis, between slabs of a Solid Water phantom (RMI company). The RMI phantom has an electron density close to that of water. The phantom slabs, 5cm thick, were placed under the film to ensure full scatter conditions. The SSD (to the phantom surface) was set at 90cm.

The films were irradiated with EDW symmetric fields, 10, 15, 20, 25, 30, 45, and 60 degrees, for field sizes of 5×5cm, 10×10cm, 15×15cm and 20×40cm, and for an asymmetric field size of 30×10cm at 60 degrees, for film calibration.

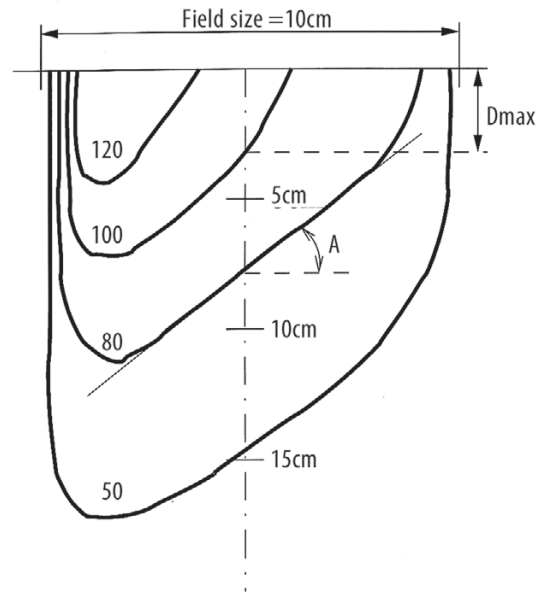

Figure 2. The Physical Wedge convention of C.B. Hughes, C.J. Karzmark and R.M. Levy. A – wedge angle, Dmax – depth of maximum dose.

The films were developed in a Protec 45 automatic photochemical film processor. The processed films were scanned in a Vidar VXR-16 scanner. The scanned images were stored in Tagged Image File Format (TIFF) with a 16 bit resolution, and spatial resolution of 72 points per inch. The beam profiles were read by the Mefysto system, taking into account the film characteristics, and subsequently compared with the profiles calculated and exported from the treatment planning systems TMS-Helax (Nucletron) and CadPlan (Varian). The film calibrations were performed using a programmed MLC step wedge and 60° dynamic wedge fields [28]. The profiles were calculated using the same geometrical conditions which were used for measurements, in virtual water phantoms, generated in the generating modules of the treatment planning systems.

The calculations were performed twice. Once with the treatment planning system CadPlan 3.1.1, and the second time with an updated version called Eclipse 7.3 and a new set of basic dosimetry data. In case of the Helax system, the first calculations were performed on version 4.0 and the second calculations on the updated version 6.1A which includes a new set of basic dosimetry data. Due to serious differences between measured and calculated beam profiles, observed for CadPlan 3.1.1 and Helax 4.0, certain modifications to the calculation algorithms were made by both manufacturers.

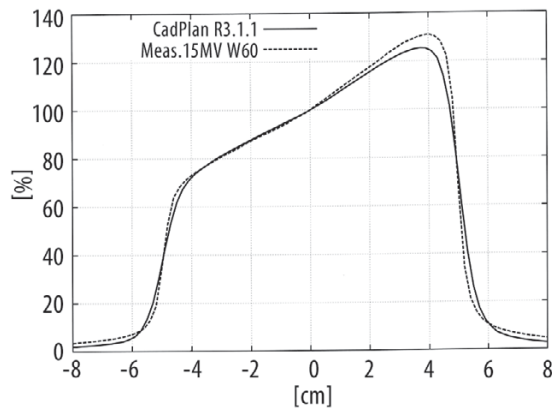

Figure 3. A measured off-axis dose profile against a calculated one using a CadPlan TPS for an EDW60 and an X-15MV beam for a field size of 10×10cm at a depth of 10cm.

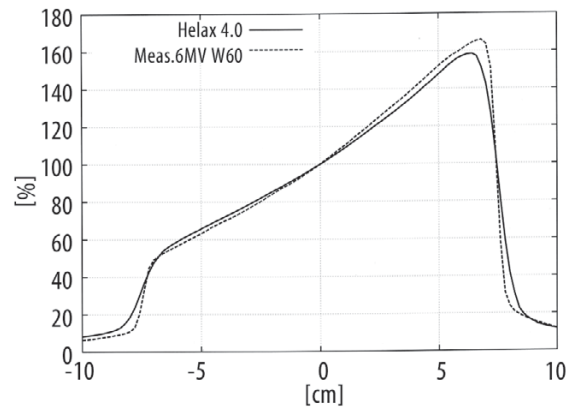

Figure 4. A measured off-axis dose profile against a calculated one using a Helax 4.0 TPS for an EDW60 and an X-6MV beam for a field size of 15×15cm at a depth of 10cm.

Table 1. Values of relative difference R between the measured and calculated profiles for different wedge angles and field sizes. The calculations were performed on a CadPlan TPS for an X-15MV beam.

CadPlan	X-15MV			
	Size [cm]			
	5×5	10×10	15×15	20×40
EDW10	1.4	2.5	1.2	1.3
EDW15	1.4	2.5	1.4	1.4
EDW20	2.0	2.7	1.9	1.3
EDW25	2.4	2.6	1.8	1.4
EDW30	2.5	2.9	2.0	1.4
EDW45	3.7	3.8	2.6	1.4
EDW60	5.0	6.0	4.7	2.7

Table 2. Values of relative difference R between the measured and calculated profiles for different wedge angles and field sizes. The calculations were performed on a CadPlan TPS for an X-6MV beam.

CadPlan	X-6MV			
	Size [cm]			
	5×5	10×10	15×15	20×40
EDW10	0.6	1.7	1.6	1.5
EDW15	0.9	1.8	2.0	1.6
EDW20	1.0	2.0	2.2	1.5
EDW25	1.6	2.9	2.4	1.7
EDW30	3.1	2.9	4.0	2.3
EDW45	3.3	3.5	5.5	4.2
EDW60	6.8	9.7	9.0	6.3

RESULTS

In Figures 3 and 4, the measured profiles of the EDW 60° dynamic wedge fields are compared with those calculated by the CadPlan 3.1.1 and Helax 4.0 treatment planning systems to demonstrate the observed differences. In the region of low dose gradient, large differences between measurements and calculations were observed in the high dose side of the profile. The calculated doses for both systems were lower than the measured doses. In Tables 1, 2, 3 and 4 the maximum relative differences (R) between measured and TPS calculated profiles are presented. The value R was

calculated according to Equation 1. Only the low dose gradient regions of the off-axis profiles were taken into account.

$$R = \max(|D_{meas}(x) - D_{calc}(x)| / D_{meas}(x)) * 100\%$$

(Equation 1)

Where

$D_{meas}(x)$ is the dose measured for the position x ,
 $D_{calc}(x)$ is the dose calculated by the treatment planning system for the position x ,
 $\max()$ is an operator returning the maximum value of an argument.

Table 3. Values of relative difference R between the measured and calculated profiles for different wedge angles and field sizes. The calculations were performed on a Helax-TMS TPS for an X-15MV beam.

Helax	X-15MV			
	Size [cm]			
	5×5	10×10	15×15	20×40
EDW10	1.4	1.3	2.4	2.0
EDW15	1.4	1.6	2.5	2.3
EDW20	2.0	1.4	2.7	2.4
EDW25	2.3	1.6	2.7	2.6
EDW30	2.5	1.5	2.9	2.7
EDW45	3.5	1.8	3.4	3.5
EDW60	4.9	3.5	5.2	5.4

Table 4. Values of relative difference R between the measured and calculated profiles for different wedge angles and field sizes. The calculations were performed on a Helax-TMS TPS for an X-6MV beam.

Helax	X-6MV			
	Size [cm]			
	5×5	10×10	15×15	20×40
EDW10	0.7	0.8	1.2	1.4
EDW15	1.1	1.3	1.4	1.4
EDW20	1.3	1.5	1.5	1.5
EDW25	1.8	1.6	1.6	1.5
EDW30	3.5	1.7	2.3	2.7
EDW45	5.4	2.6	5.9	4.6
EDW60	7.8	7.4	8.0	6.8

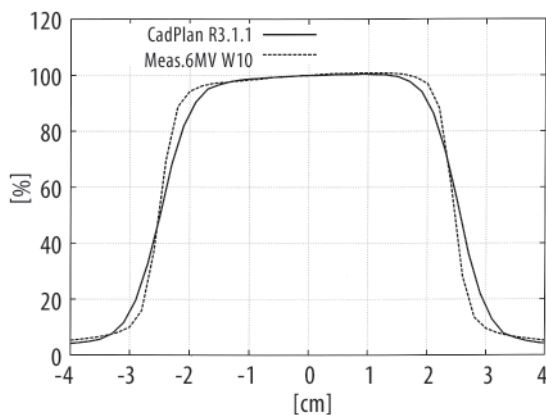

Figure 5. A measured off-axis dose profile against a calculated one using a CadPlan TPS for an EDW10 and an X-6MV beam for a field size of 5×5cm at a depth of 10cm.

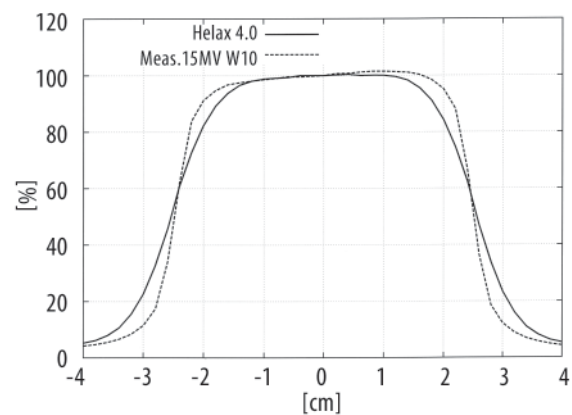

Figure 6. A measured off-axis dose profile against a calculated one using a Helax 4.0 TPS for an EDW10 and an X-15MV beam for a field size of 5×5cm at a depth of 10cm.

Larger R differences were observed for 6MV beams than for 15MV beams, at wedge angle greater than 30 degrees. At both energies, use of greater wedge angle values produced greater R differences.

In the high dose gradient regions it was more convenient to describe the discrepancies between measurements and calculations in terms of distance between the DTA curves (distance-to-agreement) [29] along the x axis. In Figures 5 and 6 the profiles for 5×5cm dynamic wedge fields are presented. Maximum DTA values in the high dose rate region were not related to either the

field size or the wedge angle and were 4mm and 4.5mm respectively for 15MV and 6MV beams for Helax and 3mm and 4mm for CadPlan.

DISCUSSION

The results of the study were reported to the manufacturers. As a result, new versions of the TPS software were installed – Helax 6.1A and Eclipse 7.3, with new calculation algorithms.

New sets of basic input data for the Clinac 2300C/D accelerators were measured for both systems and installed in both TPS.

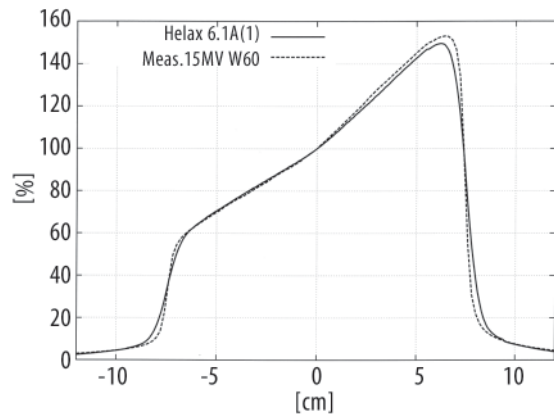

Figure 7. A measured off-axis dose profile against a calculated one using a Helax 6.1A TPS for an EDW60 and an X-15MV beam for a field size of 15×15 cm at a depth of 10cm.

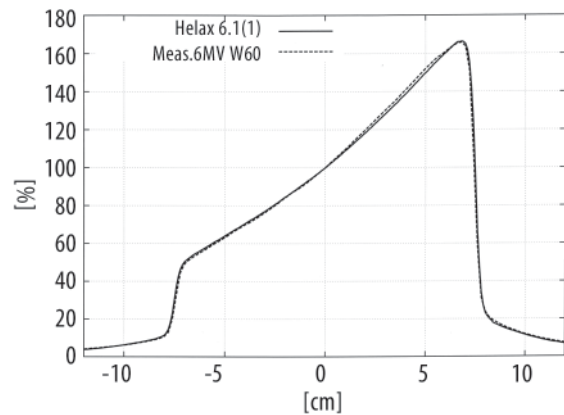

Figure 9. A measured off-axis dose profile against a calculated one using a Helax 6.1A TPS for an EDW60 and an X-6MV beam for a field size of 15×15 cm at a depth of 10cm.

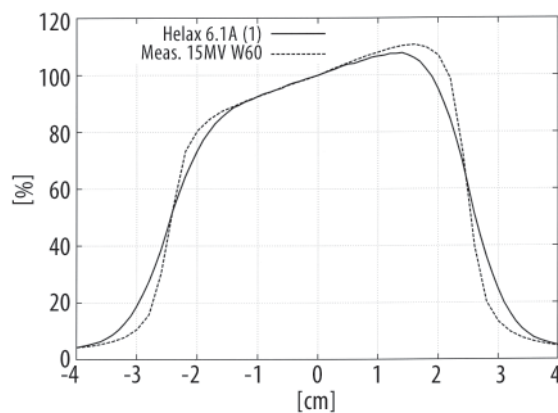

Figure 8. A measured off-axis dose profile against a calculated one using a Helax 6.1A TPS for an EDW60 and an X-15MV beam for a field size of 5×5 cm at a depth of 10cm.

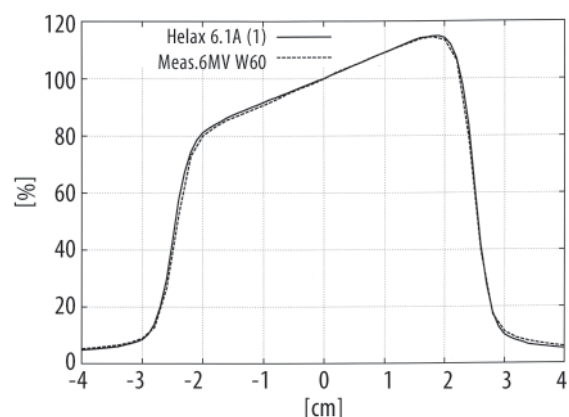

Figure 10. A measured off-axis dose profile against a calculated one using a Helax 6.1A TPS for an EDW60 and an X-6MV beam for field size of 5×5 cm at a depth of 10cm.

Subsequent comparison of measured wedge field profiles with profiles generated using Helax 6.1A showed an improved fit for 6MV beams and a worsened fit for 15MV beams. The examples of measured wedge beam profiles for 6 and 15MV beams against the profiles calculated by Helax 6.1A are presented in Figures 7–10. The differences observed only for 15MV beams were reported to the Helax manufacturer.

In the case of the Eclipse TPS there was no significant improvement, relative to CadPlan, regarding the dose difference. The DTA for the high dose gradient side of the profiles was reduced to below 1mm. Figures 11–14 show fit between measurements and calculations for the Eclipse 7.3 TPS.

After further adjustments to the EDW calculation algorithm for 15MV beams on the Helax 6.1A system, an improvement in the fit between measurements and calculations was observed. Figures 15 and 16 present results of the adjustments made by the system manufacturer.

The calculation of dose distributions for dynamic wedge fields (Enhanced Dynamic Wedge – EDW), as performed by treatment planning systems, is based on measured dosimetry data for open fields, and on Segmented Treatment Tables (STT), provided by Varian. From the manufacturer's point of view it is not necessary to carry out the complicated measurements necessary to configure EDW fields in treatment planning systems. However, without the proper dosimetry data it is not possible

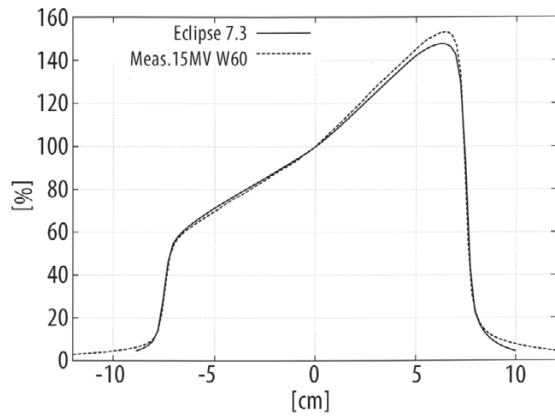

Figure 11. A measured off-axis dose profile against a calculated one using an Eclipse 7.3 TPS for an EDW60 and an X-15MV beam for a field size of 15×15cm at a depth of 10cm.

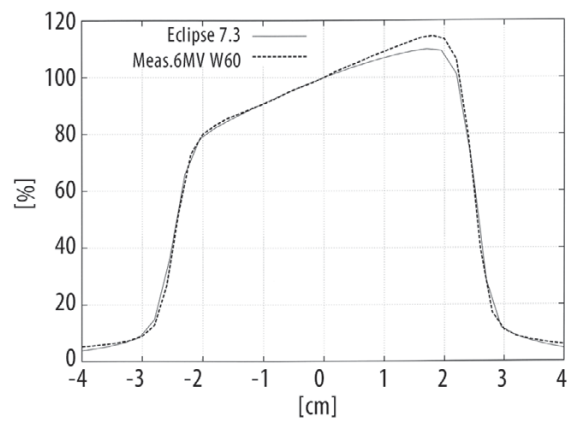

Figure 14. A measured off-axis dose profile against a calculated one using an Eclipse 7.3 TPS for an EDW60 and an X-6MV beam for a field size of 5×5cm at a depth of 10cm.

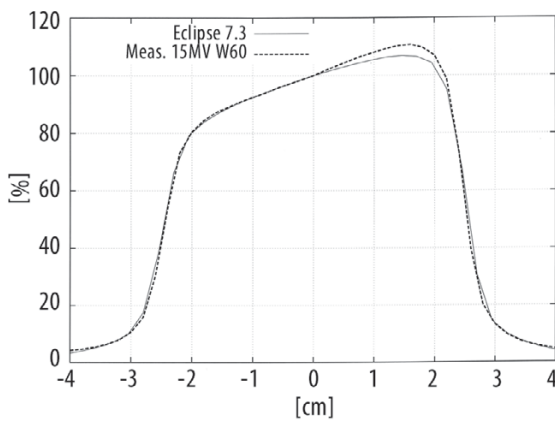

Figure 12. A measured off-axis dose profile against a calculated one using an Eclipse 7.3 TPS for an EDW60 and an X-15MV beam for a field size of 5×5cm at a depth of 10cm.

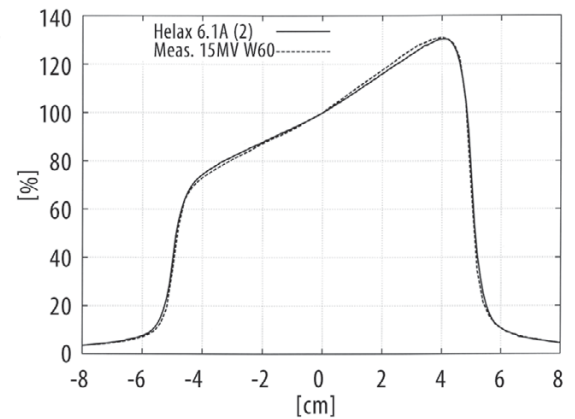

Figure 15. A measured off-axis dose profile against a calculated one using a Helax 6.1A TPS for an EDW60, after correction of the calculation model, and an X-15MV beam for a field size of 10×10cm at a depth of 10cm.

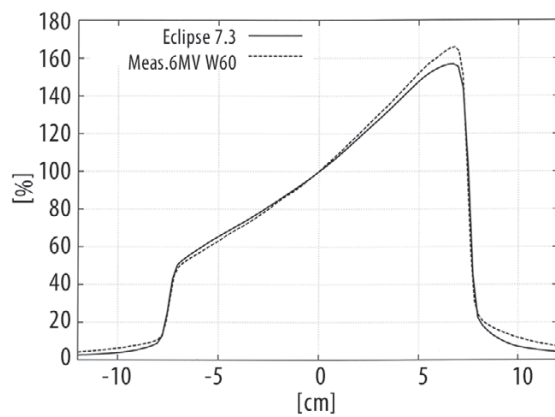

Figure 13. A measured off-axis dose profile against a calculated one using an Eclipse 7.3 TPS for an EDW60 and an X-6MV beam for a field size of 15×15cm at a depth of 10cm.

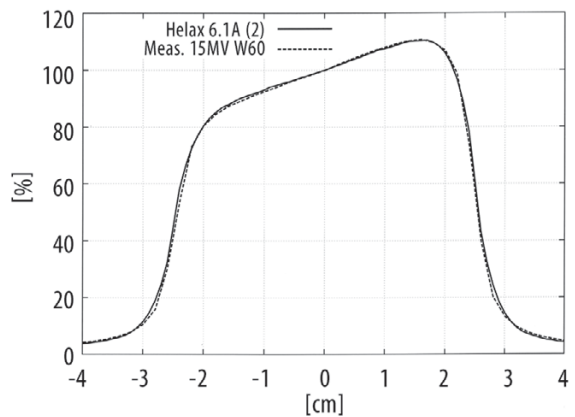

Figure 16. A measured off-axis dose profile against a calculated one using a Helax 6.1A TPS for an EDW60, after correction of the calculation model, and an X-15MV beam for a field size of 5×5cm at a depth of 10cm.

to verify the treatment planning calculations before they may be used in clinical practice.

Conventional measurements in water phantoms, using a single remote controlled ionization chamber, are not adequate in the case of dynamically configured fields. In order to measure a beam profile, the beam must be switched on many times. Linear arrays of ionization chambers or semiconductor diodes, however, require only 4 irradiations, by an EDW beam of fixed parameters, in order to achieve spatial resolution of the measurements in a profile of 2mm. However, linear arrays require considerable time for installation in a phantom. The use of dosimetry films drastically reduces the time required for verification measurements and provide better spatial resolution, in the order of tens of points per centimetre. On the other hand, films require proper processing and determination of sensitivity characteristics.

Experience gained during verification of processes in treatment planning systems confirmed the importance of dosimetry measurements to ensure proper quality assurance for dynamic wedge fields.

CONCLUSIONS

A comprehensive quality control process for treatment planning systems used in the calculation of dynamic wedge field dose distributions for a Clinac 2300 C/D resulted in the proper tuning of the calculation algorithms, by the manufacturers of these systems.

Verification measurements of dynamic wedge fields should be included as a mandatory procedure in the recommendations for the periodic testing of medical accelerators.

REFERENCES:

1. Leavitt Dennis D, Klein E: Dosimetry measurement tools for commissioning enhanced dynamic wedge. *Med Dosim*, 1997; 171-6
2. Moeller JH, Leavitt DD, Klein E: The quality assurance of enhanced dynamic wedges. *Med Dosim*, 1997; 241-4
3. Muren LP, Hafslund R, Valen H et al: Adapting the waterproof BMS-96 diode array for isodose determination of dynamic beams. *Med Dosim*, 2000; 87-91
4. Koken PW, Heukelom S, Cuijpers JP: On the practice of the clinical implementation of enhanced dynamic wedges. *Med Dosim*, 2003; 13-9
5. Kijewski PK, Chin LM, Bjarngard BE: Wedge-shaped dose distributions by computer-controlled collimator motion *Med Phys*, 1978; 426-9
6. Leavitt DD, Martin M, Moeller JH, Lee WL: Dynamic wedge field techniques through computer-controlled collimator motion and dose delivery. *Med Phys*, 1990; 87-91
7. Varian Oncology Systems. C-Series Clinac Enhanced Dynamic Wedge Implementation Guide, 1996
8. Klein EE, Low DA, Meigooni AS, Purdy JA: Dosimetry and clinical implementation of dynamic wedge. *Int J Radiat Oncol Biol Phys*, 1995; 31(3): 583-92
9. Weber L, Ahnesjo A, Nilsson P et al: Verification and implementation of dynamic wedge calculations in a treatment planning system based on a dose-to-energy-fluence formalism. *Med Phys*, 1996; 23(3): 307-16
10. Leavitt DD, Larsson L: Evaluation of a diode detector array for measurement of dynamic wedge dose distributions. *Med Phys*, 1993; 20: 381-82
11. Bidmead AM, Garton AJ, Childs PJ; Beam data measurements for dynamic wedges on Varian 600C (6MV) and 2100C (6 and 10MV) linear accelerators. *Phys Med Biol*, 1995; 40(3): 393-411
12. Leavitt DD, Huntzinger C, Etmektzoglou T: Dynamic collimator and dose rate control: enabling technology for enhanced dynamic wedge. *Med Dosim*, 1997; 167-70
13. Petti PL, Siddon RL: Effective wedge angles with a universal wedge. *Phys Med Biol*, 1985; 985-91
14. Liu HH, McCullough EC: Calculating dose distributions and wedge factors for photon treatment fields with dynamic wedges based on a convolution/superposition method. *Med Phys*, 1998; 56-63
15. Storchi P, Woudstra E, Verlinde P et al: Calculation of absorbed dose distributions from dynamic wedges. *Phys Med Biol* 1998;1497-506
16. Gibbons JP: Calculation of enhanced dynamic wedge factors for symmetric and asymmetric photon fields. *Med Phys*, 1998; 1411-18
17. Miften M, Wiesmeyer M, Beavis A et al: Implementation of enhanced dynamic wedge in the focus rtp system. *Med Dosim*, 2000; 25(2): 81-86
18. Samuelsson A, Johansson KA, Mattsson O et al: Practical implementation of enhanced dynamic wedge in the CadPlan treatment planning system. *Med Dosim*, 1997; 207-11
19. Karlsson M: Implementation of varian's EDW 5.2 on a clinac 2300C/D for use with Helax TMS 3.1 dose planning system. *Med Dosim*, 1997; 215-8
20. Chihray L, Waugh B, Zuofeng L et al: Commissioning of enhanced dynamic wedge on a ROCS RTP system. *Med Dosim*, 1997; 231-6

21. Klein EE: Treatment planning for enhanced dynamic wedge with the CMS focus/modulex treatment planning system. *Med Dosim*, 1997; 213–4
22. Beavis AW: Implementation of enhanced dynamic wedge into the multidata DSS radiotherapy treatment planning system. *Med Dosim*, 1997; 219–25
23. Gibbs G, Leavitt DD: Commissioning the varian enhanced dynamic wedge using the RAHD treatment planning system. *Med Dosim*, 1997; 227–9
24. Cramb JA, Ackerly TL: Implementation of enhanced dynamic wedge using theraplan. *Med Dosim*, 1997; 237–40
25. International Commission on Radiation Units and Measurements. Determination of Absorbed Dose in a Patient Irradiated by Beams of X or Gamma Rays in Radiotherapy Procedures, ICRU report 24, 1976
26. International Electrotechnical Commission. Medical Electron Accelerators – Functional Performance Characteristics. IEC Performance Standard 976, Geneva, 1989
27. Hughes DB, Karzmark CJ, Levy RM: Conventions for Wedge Filters Specifications. *Br J Radiol*, 1972; 45: 868
28. Chelmiński K, Rostkowska J, Kania M et al: Measurements of sensitometric curve of Kodak EDR2 and X-Omat V films using Enhanced Dynamic Wedges and Dynamic Multileaf Collimator. *Rep Pract Oncol Radiother*, 2005; 10(6): 293–300
29. Low DA, Harms WB, Mutic S, Purdy JA: A technique for the quantitative evaluation of dose distributions. *Med Phys*, 1998; 25(5): 656–61