

# Diagnostic and therapeutic recommendations of the Polish Society of Haematologists and Transfusiologists and Polish Adult Leukemia Group-CLL for chronic lymphocytic leukemia in 2021

Iwona Hus<sup>1, 2\*</sup>, Krzysztof Giannopoulos<sup>3, 4</sup>, Krzysztof Jamrozak<sup>5</sup>, Jerzy Błoński<sup>6</sup>,  
Dariusz Wołowicz<sup>7</sup>, Jacek Roliński<sup>8, 9</sup>, Piotr Smolewski<sup>10</sup>, Tadeusz Robak<sup>6</sup>

<sup>1</sup>Department of Hematology, Institute of Hematology and Transfusion Medicine, Warsaw, Poland

<sup>2</sup>Department of Clinical Transplantology, Medical University of Lublin, Lublin, Poland

<sup>3</sup>Department of Experimental Hematooncology, Medical University of Lublin, Lublin, Poland

<sup>4</sup>Department of Hematology, St. John's Cancer Center, Lublin, Poland

<sup>5</sup>Department of Hematology, Transplantology, and Internal Diseases, Central Clinical Hospital of UCK,  
Medical University of Warsaw, Warsaw, Poland

<sup>6</sup>Department of Hematology, Medical University of Lodz, Provincial Specialist Hospital M. Kopernika in Lodz,  
Lodz, Poland

<sup>7</sup>Department and Clinic of Hematology, Blood Cancer and Bone Marrow Transplantation,  
Medical University of Wroclaw, Wroclaw, Poland

<sup>8</sup>Department of Clinical Immunology, Medical University of Lublin, Lublin, Poland

<sup>9</sup>Department of Clinical Immunology, Saint John of Dukla Oncology Centre of the Lublin Region, Lublin, Poland

<sup>10</sup>Department of Experimental Hematology, Medical University of Lodz, Lodz, Poland

Article published concurrently in: Acta Haematologica Polonica 2021; 52, DOI: 10.5603/AHP.a2021.0087

## Abstract

*Chronic lymphocytic leukemia (CLL) is a disease of the elderly, with a median age at diagnosis of approximately 70 years. The natural course of the disease varies greatly, and patients with non-progressive and asymptomatic leukemia do not require treatment. The results of CLL treatment have improved significantly in recent years, mainly due to the introduction of new, more effective drugs, including BCR inhibitors and BCL2 inhibitors. The new drugs are used continuously, while venetoclax in combination with anti-CD20 antibodies is used for 24 (rituximab) or 12 (obinutuzumab) months, depending on the type of antibody and line of therapy. The choice of treatment protocol should largely depend on the assessment of 17p deletion/TP53 mutation and immunoglobulin variable heavy chain (IGVH) mutation status, which correlate with a worse response to immunochemotherapy.*

*The role of immunochemotherapy, which until recently was the mainstay of CLL treatment, has now significantly decreased. In the first-line, it is recommended only in patients without 17p deletion/TP53 mutation, with mutated IGVH. Other patients should receive novel targeted therapies.*

**Address for correspondence:** Iwona Hus, Klinika Hematologii, Instytut Hematologii i Transfuzjologii, ul. Indiry Gandhi 14, 02–776 Warszawa, Poland, phone +48 22 349 62 24, e-mail: ihus@ihit.waw.pl

This article is available in open access under Creative Common Attribution-Non-Commercial-No Derivatives 4.0 International (CC BY-NC-ND 4.0) license, allowing to download articles and share them with others as long as they credit the authors and the publisher, but without permission to change them in any way or use them commercially.

*However, at the time of the preparation of these recommendations, these therapies are not available in the first-line of treatment in Poland. Novel targeted therapies play a major role in the treatment of refractory/relapsed CLL, and immunochemotherapy is recommended primarily in patients with a long-term response to first-line therapy.*

*In this article, we present an update of the guidelines for the diagnosis and treatment of CLL, including the treatment of autoimmune complications, as well as the prophylaxis and treatment of infections, developed by the Polish Society of Haematologists and Transfusiologists and PALG-CLL Working Group.*

**Key words:** chronic lymphocytic leukemia, fludarabine, cladribine, bendamustine, chlorambucil, rituximab, obinutuzumab, ibrutinib, venetoclax, acalabrutinib, idelalisib

*Hematology in Clinical Practice 2021; 12, 2: 37–66*

## Introduction

Chronic lymphocytic leukemia (CLL) is a disease of the elderly, with a median age at diagnosis of c.70. The advanced age of CLL patients was previously associated with a poor prognosis, mainly due to comorbidities and poor tolerance of more aggressive therapies. In recent years, the treatment options for CLL have significantly expanded with the introduction of new groups of drugs: BCL2 inhibitors and B-cell receptor (BCR) signal transduction inhibitors, including Bruton's kinase inhibitors (BTK) and phosphatidylinositol-3 kinase (PI3K) inhibitors. These drugs are well tolerated by the elderly and highly effective also in patients with unfavorable prognostic factors such as 17p deletion (del17p)/*TP53* mutation and unmutated immunoglobulin heavy-chain variable region gene (*IGVH*). The selection of the appropriate treatment requires an assessment of the patient's clinical condition, age and coexisting diseases. In patients requiring therapy, it is recommended to assess factors of prognostic and predictive importance, primarily del17p/*TP53* mutation, and in cases of the first-line of treatment also the *IGVH* mutation status, because lack of mutation correlates with worse response to immunochemotherapy. The role of immunochemotherapy has significantly decreased nowadays, and it is currently recommended in the first-line only in patients without del17p/*TP53* mutation and mutated *IGVH*. The remaining patients should receive novel targeted therapies. However, at the time of the preparation of these recommendations, these therapies are not available in the first-line of treatment in Poland. In this article, we present an update of the standards of conduct in the diagnosis and treatment of CLL, including the treatment of autoimmune complications, as well as the prevention and treatment

of infections, developed by the Polish Society of Haematologists and Transfusiologists and PALG-CLL (Polish Adult Leukemia Group — Chronic Lymphocytic Leukemia). Working Group. The guidelines proposed in this paper were developed based on the results of clinical trials with different strengths of evidence and the authors' clinical experience.

## Definition and epidemiology

Chronic lymphocytic leukemia is a lymphoid cancer which is characterized by clonal proliferation of B cells and their accumulation in the peripheral blood, bone marrow, lymphoid organs, and, less frequently, in extralymphatic organs. According to the World Health Organization (WHO) classification (2016) [1], CLL is a type of mature B-cell neoplasm. It is the most common leukemia in the western world, with 5/100,000 new cases annually (SEER, Surveillance, Epidemiology, and End Results) [2]. The incidence is 6.8/100,000 in males and 3.5/100,000 in females [2]. The disease is the most common in the elderly, between 65 and 74 years of age. Approximately 70% of patients are over 65, and only 10% are under 55. The median age at diagnosis is 72 [3]. CLL patients constitute 1.3% of all cancer patients in the United States. Annual mortality from CLL is 1.1/100,000. Apart from age, the only risk factor for developing CLL is a family history. In first-degree relatives of CLL patients, the relative risk of developing CLL is up to 8.5 times higher than in the general population [4, 5]. In patients with CLL, the risk of secondary cancers is approximately three times that of the general population. The most common secondary neoplasms are skin cancer (an eight-times greater risk), lung cancer, gastrointestinal neoplasms, and hematological neoplasms [6].

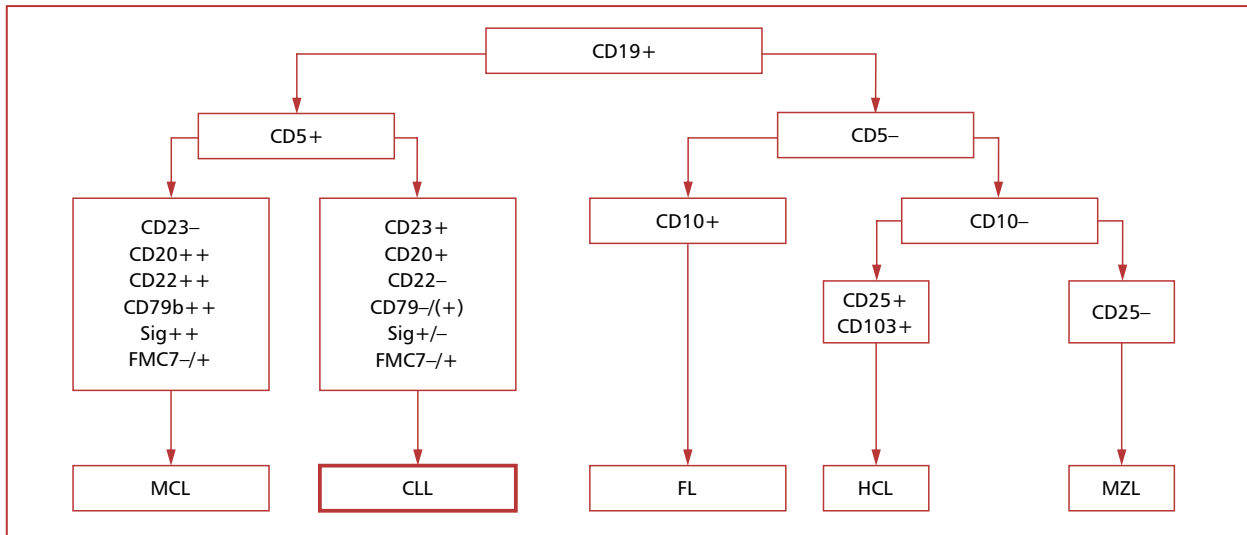

**Figure 1.** Simplified algorithm for the differential cytometric diagnosis of chronic lymphocytic leukemia (CLL); MCL — mantle cell lymphoma; FL — follicular lymphoma; HCL — hairy cell leukemia; MZL — marginal zone lymphoma

### Diagnostic criteria

The main criterion for the diagnosis of CLL is the presence of at least 5 G/L of clonal B-cells in the peripheral blood, confirmed by immunophenotypic examination of light chains (kappa, lambda) [7]. Leukemic CLL cells are mostly small, mature lymphocytes, with a narrow border of cytoplasm and dense nuclear chromatin. This population also includes larger, atypical, nuclear-indentated cells or prolymphocytes, the percentage of which should not exceed 55% of all peripheral blood lymphocytes. The presence of a higher percentage of prolymphocytes supports the diagnosis of chronic B-cell prolymphocytic leukemia (B-cell PLL) [7].

CLL cells co-express typical B-cell antigens (CD19, CD20) with T-cell antigen CD5 as well as CD23, CD43, and CD200 antigens [8]. Expression of CD20, CD79a, and surface immunoglobulin antigens is weaker than in normal B cells. In 50% of cases, B-cell prolymphocytic leukemia cells do not express CD5, while CD20 and surface immunoglobulin are expressed [7].

Patients with lymphadenopathy and/or splenomegaly, with B-cells with typical CLL immunophenotype in the peripheral blood, but less than 5 G/L, meet the diagnostic criteria of small lymphocytic lymphoma (SLL) [7]. A final diagnosis of SLL requires histopathological examination of the affected tissue. According to the WHO, CLL and SLL are separate clinical manifestations of the same disease [1].

The presence of less than 5 G/L of clonal B cells in the peripheral blood, without accompanying lymphadenopathy or organomegaly, cytopenia or systemic symptoms, allows the diagnosis of monoclonal B-cell lymphocytosis (MBL). Annually, 1–2% of MBL cases progress to CLL [9].

A simplified diagram of the cytometric differential diagnosis of CLL with leukemic forms of other B-cell lymphomas is presented in Figure 1.

Bone marrow examination is not needed to diagnose CLL. However, it should be performed in patients with cytopenia to diagnose its cause (e.g. displacement of normal hematopoietic cells by leukemic cells, drug toxicity or immunocytopenia), as well as in the case of inconclusive results of immunophenotyping [7, 8]. Typically, bone marrow in CLL shows at least 30% diffuse or follicular infiltration of the lymphoid cells. In patients with concomitant lymphadenopathy and inconclusive immunophenotyping result, an open biopsy of the lymph node should be performed.

### Patient evaluation at CLL diagnosis

Initial evaluation of a patient diagnosed with CLL should include a medical history, physical examination including lymph nodes, liver, and spleen, laboratory tests, and, if necessary, diagnostic imaging. Attention should be paid to the general symptoms related to the disease (fever for no apparent cause > 38.0°C for more than two weeks, night sweats, weight loss over 10% of the

**Table 1.** Clinical staging of chronic lymphocytic leukemia, according to Rai and Binet classifications (based on [10–12])

Classification	Clinical period/risk group		Criteria
Rai	0	Low risk	Lymphocytosis*
	I	Intermediate risk	Lymphocytosis + lymphadenopathy
	II		Lymphocytosis* + splenomegaly and/or hepatomegaly (with or without lymphadenopathy)
	III	High risk	Lymphocytosis* + anemia (Hb < 11.0 g/dL)
	IV		Lymphocytosis* + thrombocytopenia (PLT < 100.0 g/dL)
Binet	A		Involvement of ≤ 2 node areas/organs**
	B		Involvement of ≥ 3 node areas/organs**
	C		Anemia and/or thrombocytopenia (Hb < 10 g/dL, and/or PLT < 100 G/L)

\*Absolute peripheral blood lymphocyte count >5,000/μL; \*\*enlarged head and neck lymph nodes and/or axillary nodes and/or inguinal nodes and/or spleen and/or liver (see text for details); Hb — hemoglobin; PLT — platelets

initial weight in the last six months, progressive weakness), recurrent infections and comorbidities that may influence therapeutic decisions. Laboratory tests include complete blood count with a manual blood smear review, biochemical tests with the assessment of kidney and liver function, immunoglobulin levels and direct antiglobulin test (DAT). In routine clinical practice, in asymptomatic patients it is not necessary to perform imaging diagnostics such as ultrasound scan, computed tomography (CT), positron emission tomography/computed tomography (PET/CT) or magnetic resonance imaging (MRI). However, these tests are required in prospective clinical trials. PET/CT examination is recommended in patients with suspected Richter's syndrome to determine the optimal biopsy site.

During diagnostics, the clinical stage of CLL should be determined using one of the two equivalent clinical staging systems: Rai or Binet [10, 11]. Both classifications are based on the results of blood count and physical examination. According to the current recommendations, the modified, 3-grade, Rai's staging system should be used instead of the original 5-grade system [7, 12]. Binet's staging system depends on the number of nodal areas involved, including:

- 1) enlarged lymph nodes in the head and neck, including Waldeyer's ring (counted as one area even if more than one node is enlarged at that location);
- 2) enlarged axillary lymph nodes (counted as one area even with bilateral involvement);
- 3) enlarged inguinal lymph nodes (counted as one area even with bilateral involvement);
- 4) spleen palpable on physical examination;
- 5) liver enlarged on physical examination.

The Rai and Binet classifications are set out in Table 1 [10–12].

### Prognostic factors

Rai or Binet staging is still an important prognostic factor in CLL patients, although its importance is decreasing with the introduction of increasingly effective therapies. Neither staging system allows the identification of patients with an unfavorable prognosis in the early stages of leukemia. Parameters of particular prognostic and predictive importance include del17p/*TP53* mutation and *IGVH* mutation status. The presence of del17p/*TP53* mutation is associated with the worst prognosis in patients treated with immunochemotherapy, resulting in overall survival (OS) of 2–5 years [13–15]. The treatment outcomes of these patients improved significantly due to the introduction of targeted therapies with BCR and BCL2 inhibitors [16–18]. However, the prognosis still remains poor compared to patients without these mutations. The frequency of del17p/*TP53* mutation increases with the progression of CLL, so testing should be performed prior to each subsequent line of treatment. Firstly, del17p should be evaluated [using fluorescence *in situ* hybridization (FISH)], and if the test result is negative molecular evaluation for *TP53* mutation should be performed [Sanger or next generation sequencing (NGS)]. The negative prognostic value of del11q (detected using FISH) has been significantly reduced due to the addition of rituximab to fludarabine and cyclophosphamide (FCR) and new targeted therapies [15, 16, 19]. Evaluation of other mutations such as: *NOTCH1*, *SF3B1*, *BIRC3*, *RPS15* and the presence of complex karyotype

(defined as  $\geq 3$  or  $\geq 5$  independent cytogenetic aberrations), which are associated with an unfavorable prognosis in patients without del17p/*TP53* mutation, is currently not applicable in clinical practice.

The lack of IGVH mutation, which is found in c.60% of CLL patients, has a significant negative prognostic and predictive value [20]. *IGVH* genes are defined as unmutated when their variability compared to the germline is  $< 2\%$ . The absence of IGVH mutations is associated with a more aggressive course of CLL, shorter survival [20], more frequent occurrence of del17p and del 11q, and a short response to FCR immunochemotherapy [21–24]. Subgroup analysis of patients treated in clinical trials with new targeted therapies (BCR and BCL2 inhibitors) showed that these drugs are effective regardless of *IGVH* mutation status [19, 25–28]. According to International Workshop on Chronic Lymphocytic Leukemia (iwCLL) and European Society for Medical Oncology (ESMO) recommendations, *IGVH* mutation status should be assessed before the initiation of first-line treatment [7, 8]. The mere presence of unfavorable prognostic factors is not an indication for the initiation of treatment.

Negativity of minimal residual disease (MRD), defined as the presence of  $< 1$  CLL cells/10,000 leukocytes, is an important prognostic factor evaluated after the treatment. MRD can be assessed in blood and bone marrow with multicolor flow cytometry, real-time quantitative polymerase chain reaction (RQ-PCR), digital droplet PCR (ddPCR), and high-throughput sequencing (HTS). The first two methods are now standardized [29]. MRD negativity is a sign of deep response, which results in longer progression-free survival (PFS) and OS, as demonstrated in the CLL8 study in patients treated with fludarabine and cyclophosphamide (FC) and FCR. A higher incidence of MRD eradication was observed in patients treated with FCR immunochemotherapy [30]. The results of a retrospective single-center analysis of patients treated in 1997–2006 showed a significant effect of MRD eradication on 10-year survival, regardless of the type of therapy [31]. The correlation between MRD eradication and longer PFS has also been demonstrated in studies of venetoclax in combination with the anti-CD20 monoclonal antibodies, rituximab (MURANO study) and obinutuzumab (CLL14 study) [19, 32, 33]. In both cases, the rates of MRD eradication were significantly higher compared to immunochemotherapy, and obtaining MRD eradication, regardless of the treatment method, was associated with a longer PFS. Currently, the evaluation of MRD is only recommended in clinical

trials, but MRD eradication is likely to influence treatment decisions in future.

### Indications for treatment initiation

The decision to start treatment is aimed at extending the patient's life as well as improving not only the quality of life, but also the quality of the treatment itself. Despite enormous progress in understanding the biology of leukemia increasing the possibility of exact prediction of an unfavorable prognosis, the primary indication for treatment is staging, using the Rai or Binet classifications. Although the predictive value of some new genetic and biological markers for overall survival goes down in people aged over 75, the majority of CLL population, del17p, *TP53* and *IGVH* mutation status should be taken into account when choosing therapy also in this group of patients. The criteria for treatment initiation in clinical trials may differ from those adopted in everyday clinical practice. Except for clinical trials, treatment should not be initiated in patients with newly diagnosed CLL in the early stages (i.e. Rai stage 0 or Binet A stage) without evidence of disease progression. These patients should be followed up, with disease status monitored every 3–12 months. Patients in the intermediate stage of disease, i.e. Rai stage I and II or Binet B stage, require close monitoring of certain leukemia parameters every 3–9 months, and in this group treatment should be initiated in the presence of signs of active disease or progression. Patients with advanced CLL (Rai III/IV or Binet C) require anti-leukemic treatment. If cytopenia is caused solely by the presence of autoantibodies, immunosuppressive therapy (glucocorticosteroids) is indicated, and antileukemic therapy is indicated if immunosuppressive therapy is ineffective. The criteria proposed by Hallek et al. [7] should be used to assess CLL activity. Initiation of anti-leukemic therapy is indicated if the symptoms set out in Table 2 are observed.

### Pre-treatment evaluation

In patients with CLL who are offered the initiation of treatment, the following tests are recommended [7, 8]:

- history and physical examination with assessment of lymph nodes, liver, and spleen;
- assessment of general condition and comorbidities;
- complete blood count with manual blood smear review;

**Table 2.** Indications for treatment initiation according to International Workshop on Chronic Lymphocytic Leukemia (iwCLL) (source [7])

1. Progressive bone marrow involvement as manifested by anemia and/or thrombocytopenia [assumed hemoglobin (Hb) cut-off point < 10 g/dL (< 6.21 mmol/L) or platelet count < 100 G/L]. However, these parameters should be reproducible and systematically decreasing, because often, especially in platelet count, parameter is only slightly reduced, up to < 100 G/L, but stable for a long time, which should not be considered an indication for treatment. In sudden and extremely low cytopenia, differential diagnosis should include autoimmune diseases, and appropriate laboratory workup should be planned
2. Significant ( $\leq 6$  cm below costal margin), progressive or symptomatic splenomegaly
3. Significant ( $\leq 10$  cm in long axis), progressive or symptomatic lymphadenopathy
4. Rapid increase in lymphocyte count — increase of more than 50% in two months or doubling of WBC in less than six months (if baseline lymphocyte count did not exceed 30 G/L). Other possible causes of sudden increase in lymphocyte count or progression of lymphadenopathy (including SARS-CoV-2 infection) should be ruled out. An absolute number of lymphocytes, even a very high number, without other symptoms, is not a sufficient indication for treatment initiation. This definition indicates necessity of examining patient and assessing blood count at least every six months
5. Autoimmune anemia and/or immune thrombocytopenia refractory to corticosteroid therapy or other standard treatments
6. One or more systemic symptoms depending on underlying disease, defined as:
  - unintentional weight loss of  $\geq 10\%$  in the last six months
  - significant fatigue (ECOG PS  $\geq 2$ ; inability to work or perform normal activities)
  - fever  $> 38.0^\circ\text{C}$  for three weeks or more with no other indication of infection
  - night sweats for more than one month without any other evidence of infection. A common problem in CLL patients is increased susceptibility to infection. Unless other symptoms of active disease coexist, it is not an indication for anti-leukemic treatment
7. Symptomatic extra-nodal localization

Hb — hemoglobin; PLT — platelets; SARS-CoV-2 — severe acute respiratory syndrome-related coronavirus 2; ECOG PS — the Eastern Cooperative Oncology Group of performance status

- bone marrow examination (fine needle biopsy/trephine biopsy) is indicated in cases of cytopenia of unknown cause and in clinical trials. Bone marrow biopsy may also be used as a baseline parameter in assessing response to treatment;
- biochemical tests to assess organ function (liver and kidney tests) and possibly exclude causes of anemia other than CLL;
- immunoglobulin levels (IgA, IgG, and IgM) in serum;
- direct Coombs test [direct antiglobulin test (DAT)], haptoglobin concentration;

- diagnostic imaging (outside clinical trials, if needed): chest X-ray, abdominal ultrasound, CT/MRI; as part of clinical trials: chest, abdomen, and pelvis CT. Diagnostic imaging (CT, MRI) may be helpful in clinical practice in assessing tumor mass and risk of tumor lysis syndrome, especially before starting venetoclax treatment, as well as in assessing response to treatment. In older patients, abdominal ultrasound and chest X-ray should be considered instead of CT [8];
- virological tests [HBs antigen, anti-HBc total, anti-hepatitis C virus (HCV), anti-human immunodeficiency (HIV) antibodies).

It is also advisable to perform other tests useful for assessing the risk of an unfavorable course of disease, including:

- cytogenetics (FISH) for del17p and molecular tests for *TP53* mutation (in absence of del17p): at least exons 4–10, recommended 2–11; < 6 months before starting each line of treatment [8];
- *IGVH* mutation status [7, 8] before initiation of first-line of treatment;
- serological markers:  $\beta_2$ -microglobulin, lactate dehydrogenase (LDH).

## Treatment

### Antileukemic drugs used in CLL Alkylating agents

Chlorambucil, the drug with the longest history in CLL, allows for the reduction or resolution of symptoms in 30–70% of patients, but complete remission (CR) is observed rarely (2–10%). Chlorambucil is used in various schedules (Table 3). In British studies, the highest response rate and the longest PFS were observed with the use of chlorambucil at 10 mg/m<sup>2</sup> from days 1 to day 7 of a 28-day cycle (Table 3) [34]. Currently, chlorambucil monotherapy is used rarely, and only in patients whose old age and/or comorbidities do not allow the use of immunochemotherapy.

### Purine analogs

Purine analogs (fludarabine, cladribine, pentostatin) are a group of cytostatics with the most pronounced therapeutic activity in CLL. However, they induce numerous adverse effects, including hematological complications (neutropenia, thrombocytopenia, anemia), autoimmune hemolytic anemia, increased incidence of infections, including opportunistic [*Pneumocystis carinii*, cytomegalovirus (CMV), *varicella zoster virus*] associated

**Table 3.** Selected treatment protocols used in patients with chronic lymphocytic leukemia

Protocol/ drug	Dose	Administration route	Days	Notes	References
Chlorambucil	0.1 mg/kg bw 0.4–0.8 mg/bw 10 mg/m <sup>2</sup> 40 mg/m <sup>2</sup>	Oral	Continuous infusion 1 and 15 1–7 1	28-day cycles 28-day cycles 28-day cycles	[34]
FCR F CY R	25 mg/m <sup>2</sup> /40 m <sup>2</sup> 250 mg/m <sup>2</sup> 375 mg/m <sup>2</sup> (cycle 1) 500 mg/m <sup>2</sup> (cycles 2–6)	i.v./oral i.v., oral i.v.	1–3 1–3 1 1	28-day cycles	[15]
CCR C CY R	0.12 mg/kg bw 650 mg/m <sup>2</sup> 375 mg/m <sup>2</sup> (cycle 1) 500 mg/m <sup>2</sup> (cycles 2–6)	Oral Oral i.v.		28-day cycles	[29, 35]
BR B R	90 (70)* mg/m <sup>2</sup> 375 mg/m <sup>2</sup> (cycle 1) 500 mg/m <sup>2</sup> (cycles 2–6)	i.v. i.v.	1–2 1 1	28-day cycles	[43, 45]
Chlorambucil + rituximab	0.5 mg/kg bw or 10 mg/m <sup>2</sup> 375 mg/m <sup>2</sup> (cycle 1) 500 mg/m <sup>2</sup> (cycles 2–6)	Oral Oral i.v.	1, 15 1–7 1	28-day cycles, up to six cycles	[46, 49]
Chlorambucil + obinutuzu- mab	0.5 mg/kg 1,000 mg	Oral i.v.	1, 8, 15 (first cycle) 1 (cycles 2–6)	28-day cycles, up to six cycles One infusion over two days	[46]
Ibrutinib	420 mg/day	Oral	Continuous treatment	Until progression or unacceptable toxicity	[50]
Idelalisib + rituximab	2 × 150 mg 375 mg/m <sup>2</sup> (cycle 1) 500 mg/m <sup>2</sup> (cycles 2–6)	Oral i.v.	Continuous treatment	Until progression or unacceptable toxicity	[58]
Venetoclax	20–400 mg	Oral	Continuous treatment	Until progression or unacceptable toxicity	[61]
Venetoclax + rituximab	20–400 mg 375 mg/m <sup>2</sup> (D1, C1), 500 mg/m <sup>2</sup> (D1, C2–C6) every four weeks after end of titration period	Oral i.v.	24 months 6 cycles		[32]
Venetoclax + obinutuzu- mab	20–400 mg 1,000 mg every four weeks after end of titration period	Oral i.v.	12 months 6 cycles		[19]
Acalabrutinib	150 mg twice daily	Oral	Continuous treatment	Until progression or unacceptable toxicity	[56]

\*Treatment of relapse; A — alemtuzumab; B — bendamustine; FCR — fludarabine, cyclophosphamide, rituximab; i.v. — intravenous; BR — bendamustine, rituximab

with myelosuppressive and immunosuppressive effects and an increased risk of secondary tumors. The risk of serious adverse events is greater in the elderly due to slower renal excretion of the fludarabine metabolites. The incidence of autoimmune complications is significantly lower when

purine analogs are used in combination with cyclophosphamide and rituximab compared to monotherapy [15, 35, 36]. Fludarabine should not be used in patients with creatinine clearance < 30 mL/min, and a dose reduction of 50% is indicated when the clearance is < 70 mL/min. Particular attention

should be paid to recurrent infections due to the strong immunosuppressive effect of fludarabine and poor functioning of the immune system in the elderly.

### **Bendamustine**

Bendamustine is a cytostatic drug combining the properties of alkylating compounds and purine analogs. It is now widely used in the treatment of lymphoproliferative neoplasms, most often in combination with rituximab. The most important side effects of bendamustine are myelosuppression, infections, nausea, vomiting, and skin lesions. The hematological toxicity of bendamustine is greater than that of chlorambucil, but less than that of purine analogs. Bendamustine, unlike fludarabine, can be used in full doses in patients with renal failure. Modification of bendamustine dose is recommended only in cases of severe kidney disease (creatinine clearance < 10 mL/min).

### **Immunochemotherapy**

#### ***FCR/CCR (fludarabine/cladribine, cyclophosphamide, rituximab)***

Based on the results of the CLL8 study, which showed a significantly higher response rates and longer PFS and OS in patients receiving FCR immunochemotherapy compared to FC chemotherapy, immunochemotherapy with purine analogs (fludarabine, cladribine) and cyclophosphamide in combination with rituximab (FCR/CCR) has been recognized as the standard of care in first-line treatment in younger patients in good general condition without significant comorbidities (Table 4) [15]. Due to the significantly deeper response obtained in patients who received six, rather than three, cycles of FCR, it is recommended to administer six cycles of treatment if it is well tolerated [30]. The FCR regimen is highly toxic, especially in terms of cytopenia and infections. According to the European Organization for Research and Treatment of Cancer (EORTC) and the National Cancer Center Network (NCCN), the risk of febrile neutropenia during FCR exceeds 20%, which is an indication for primary prophylaxis with granulopoiesis stimulating factors [37, 38]. Although no randomized trials comparing FCR to RCC (rituximab, cladribine, cyclophosphamide) have been conducted so far, we believe that both regimens can be used alternatively [39]. Direct comparison of FC and CC did not reveal any differences in the effectiveness and toxicity of both regimens [40].

Immunochemotherapy is ineffective in patients with del17p/*TP53* mutation. In patients with del17p treated in the CLL8 trial, PFS was 11.3

months, 3-year OS was 38%, and median OS was 33.1 months compared to 51.8 months, 87% and 78.7% in the general study population, respectively [15]. The results of the CLL8 study after 5.9 years of follow-up showed significantly worse results of FCR immunochemotherapy also in patients with unmutated *IGVH*. The PFS rate was 33.1%, versus 66.6% in patients with mutated *IGVH* in whom the median OS was not achieved (except for the del17p group) [24]. FCR immunochemotherapy remains the treatment of choice in the first-line treatment of patients with mutated *IGVH* [8].

Patients with relapsed/refractory CLL not previously treated with fludarabine benefited from the addition of rituximab to the FC regimen in terms of duration of PFS, without significant differences in overall survival (REACH study) [41]. Similar efficacy was demonstrated for the CCR regimen, with a 78% response rate in patients with relapsed/refractory CLL after multiple lines of treatment [42].

#### ***Bendamustine and rituximab***

A combination of bendamustine and rituximab (BR) allows for high response rates in both relapsed/refractory CLL and first-line treatment [43, 44]. The German group CLL10 has shown that FCR is more effective in inducing complete remissions (CR), and results in longer PFS (Table 4) and eradication of MRD in the first-line treatment of CLL [45]. In patients > 65 years the efficacy of both regimens in terms of PFS was comparable. FCR regimen was significantly more toxic, including hematological toxicity (90% vs. 67%), severe neutropenia (84% vs. 59%) and infections (39% vs. 25%), especially in elderly patients. In patients treated with the BR regimen, routine primary prophylaxis of febrile neutropenia is not recommended, although it should be considered, especially when using the BR regimen in patients with relapsed/refractory CLL.

#### ***Chlorambucil in combination with anti-CD20 monoclonal antibodies***

In phase III clinical trials, chlorambucil in combination with anti-CD20 antibodies (rituximab, obinutuzumab, ofatumumab) has been shown to be more effective compared to chlorambucil in monotherapy in the first-line treatment of patients ineligible for intensive immunochemotherapy with purine analogs (Table 4) [46–49]. The CLL11 study showed that obinutuzumab is more effective than rituximab in terms of CR, PFS, and MRD eradication [46, 47]. The last update of the results of the CLL11 study, presented at the European



Hematology Association (EHA) 2018 meeting, demonstrated a significantly longer OS in patients treated with obinutuzumab compared to patients treated with rituximab ( $p < 0.0001$ ) [48]. In this study, the only  $\geq 3^{\text{rd}}$  grade adverse reactions that were significantly more common in patients treated with obinutuzumab were infusion-related adverse events. Appropriate premedication, dividing the first dose into two separate infusions administered on consecutive days, and discontinuing blood pressure-lowering drugs, allow serious treatment complications to be avoided.

### BCR signaling inhibitors

Inhibitors of BCR signaling approved in the European Union (EU) for the treatment of CLL include the BTK inhibitors ibrutinib and acalabrutinib, and  $\delta$  isoform of phosphatidylinositol-3 kinase (PI3K $\delta$ ) — idelalisib. Summary of product characteristics (SmPC) indications for ibrutinib include both first-line and refractory/relapsed CLL treatment. The efficacy of ibrutinib in patients with relapsed/refractory CLL was assessed in a phase Ib/II study (PCYC-1102) [50] and a randomized phase III study (RESONATE) in which ofatumumab was used in the control arm (Table 4) [51]. The response rate in the PCYC-1102 study was 88%, including 2% CR, 68% partial remission (PR), and 18% partial response with lymphocytosis (PR-L). The response rates were similar regardless of the presence or absence of del17p/*TP53* mutation [50]. The median PFS was 52 months, and the OS rate after 7 years of follow-up was 55% [52].

In the RESONATE study, patients treated with ibrutinib had a very significantly higher response rate (63% vs. 4%,  $p < 0.001$ ) and a significantly longer PFS (44.1 vs. 8.1 months,  $p < 0.001$ ) [51]. An update of the RESONATE study results shows that the benefits of ibrutinib are maintained and the risk of progression is reduced by 89% compared to ofatumumab treatment. Median progression-free survival was significantly longer in patients randomized to the ibrutinib arm compared to ofatumumab (44.1 vs. 8.1 months). The benefits of ibrutinib versus ofatumumab were maintained in the high-risk population with del17p, *TP53* mutation, del11q and/or unmutated *IGVH* genes. Overall survival, censored for crossover, was longer on ibrutinib than ofatumumab [hazard ratio (HR): 0.639; 95% CI: 0.418–0.975] [53]. The efficacy of ibrutinib was analyzed in patients with relapsed/refractory CLL progressing on their last treatment with venetoclax. Median PFS and OS after initiation of BTK inhibitors treatment were 34 and 42

months, respectively. BTK inhibitors (ibrutinib,  $n = 21$ ; zanubrutinib,  $n = 2$ ) have brought lasting benefits in patients with the *Gly101Val* mutation associated with venetoclax resistance [54].

The efficacy of ibrutinib in first-line treatment was assessed in RESONATE-2, a randomized, phase III trial performed in a population of patients aged  $\geq 65$ . Ibrutinib was shown to be significantly more effective in terms of response rates, PFS, and OS compared to chlorambucil, regardless of the presence of del17p and the *IGVH* mutation status (Table 4) [55]. Moreover, a significant improvement in hematological parameters (anemia, thrombocytopenia) was observed more frequently in patients treated with ibrutinib [55]. In subsequent phase III clinical trials, ibrutinib regimens were compared to first-line immunochemotherapy regimens. In the iLLUMINATE study, patients aged 65 or younger with comorbidities were treated with ibrutinib and obinutuzumab versus chlorambucil and obinutuzumab. The response rates (ORR, CR, MRD negativity) were significantly higher (91%, 41%, 35% vs. 81%, 16% vs. 25%, respectively) and the median PFS was significantly longer in patients treated with ibrutinib (not achieved after 19 months), irrespective of risk factors (del17p/*TP53* mutation, *IGVH* mutation status). There was no difference in OS, and it remains unclear whether the addition of obinutuzumab to ibrutinib is more effective than ibrutinib in monotherapy [28]. In the E1912 trial, patients up to the age of 70 received first-line treatment of ibrutinib and rituximab or FCR immunochemotherapy. Both PFS and 3-year OS were significantly longer in patients treated with ibrutinib (89.4% vs. 72.9%,  $p < 0.001$ ; 98.8% vs. 91.5%,  $p < 0.001$ ), but subgroup analysis showed that the real benefit of ibrutinib treatment is achieved by patients with unmutated *IGVH*. 3-year PFS in the group with mutated *IGVH* treated with ibrutinib was 87.7% compared to 88% in FCR-treated patients. In patients with unmutated *IGVH*, 3-year PFS was 90.7% versus 62.5%, respectively [26]. In the third ALLIANCE study, patients over 65 received first-line treatment with ibrutinib in monotherapy, ibrutinib in combination with rituximab, or a BR regimen. The 2-year PFS rate was significantly higher in patients treated with ibrutinib-based regimens (87%, 88%, and 74%), with no evidence of PFS benefit from the addition of rituximab to ibrutinib. Patients with del17p particularly benefited from ibrutinib. There was no difference in overall survival of patients treated with different regimens after 38 months of follow-up [27].

**Table 4.** Selected phase III clinical trials in treatment of chronic lymphocytic leukemia

Study	Protocol	Number of participants	Median age	ORR [%]	CR [%]	PFS (months)	OS (months)	Reference
CLL8 Hallek (2010)	FC	409	61	80	22	33	86	[15]
	FCR	408	61	90*	44*	52*	NA* (after 6 years)	[24]
CLL10 Eichhorst (2016)	FCR BR	282	62	95	40	55.2	91%	[45]
		279	61	96	31*	41.7*	92% (after 3 years)	
CLL11 Goede (2014)	Chl	118	72	31.4*	0*	11.1*	ND	[46]
	R + Chl	233	73	65.7*	7.3*	16.3*	73.1*	[47]
	G + Chl	238	74	77.7*	22.3*	26.7*	NA*	[48]
RESONATE-2 Burger (2015)	Chl	133	73	37	2	15*	68%	[25]
	Ibrutinib	136	72	92*	30	NA*	83% (after 5 years)	[55]
ECOG1219	FCR	175	56.7	81.1	30.3	72.9%	91.5%	[26]
	Ibrutinib + ituximab	354	56.7	95.8*	17.2*	89.4%* (after 3 years)	98.8% (after 3 years)	
ALLIANCE	BR	183	70	81	26	74%	95%	[27]
	Ibrutinib	182	70	93	7	87%	90%	
	Ibrutinib + rituximab	182	71	94	12	88% (after 2 years)	94% (after 2 years)	
ILLUMINATE	Chlorambucil + obinutuzumab	116	72	88	8	19	86%	[28]
	Ibrutinib + obinutuzumab	113	70	73	19*	NA*	85% (after 30 months)	
CLL14	Obinutuzumab + chlorambucil	216	72	71.3	23.1	35.4%	83.1	[19]
	Venetoclax + obinutuzumab	216	72	84.7	49.5	74% After 48 months	85.3 After 48 months	[64]
ELEVATE-TN	Obinutuzumab + chlorambucil	177	71	79	5	22.6	92	[57]
	Acalabrutinib	179	71	86	1	NO	95	
	Acalabrutinib + obinutuzumab	179	71	94	13	NO 93 vs. 87 vs. 47 after 24 months	95 after 24 months	
RESONATE	Ofatumumab	196	67	4	0	8.1	65.1	[51]
	Ibrutinib	195	67	91	11	44.1*	67.7*	[53]
MURANO	BR	195	65	72.3	3.6	17	62.2	[32, 33]
	VenR	194	65	92.3*	8.2*	53.6* 84.9 36.3 after 24 months	82.1 After 5 years	
ASCEND	Investigator's choice**	155	68	81	ND	88	91	[29]
	Acalabrutinib	155	67	75	ND	68 (after 12 months) 16.5 NA*	94 After 12 months	

\*Statistically significant difference, \*\*BR — 36 patients, idelalisib + rituximab — 119 patients; ORR — overall response rate; CR — complete remission; PFS — progression-free survival; OS — overall survival; FC — fludarabine, cyclophosphamide; FCR — fludarabine, cyclophosphamide, rituximab; NA — not achieved; BR — bendamustine, rituximab; Chl — chlorambucil; ND — no data; R — rituximab; G — obinutuzumab; VenR — venetoclax, rituximab

Ibrutinib is well tolerated. Most of the adverse reactions in clinical trials have been described as grade 1–2. The most common adverse effects are diarrhea, fatigue, muscle and joint pain, infections, bleeding complications, hypertension, and atrial fibrillation.

In January 2020, acalabrutinib, a selective reversible BTK inhibitor, was registered by the European Medicines Agency (EMA) for both first-line treatment (in monotherapy or in combination with obinutuzumab) and in patients who had received at least one previous therapy (in monotherapy). In the ASCEND study, the efficacy and safety of acalabrutinib in the treatment of patients with relapsed/refractory CLL who had not previously received BTK and BCR inhibitors was compared to a treatment at the investigator's choice (BR or idelalisib and rituximab). The median PFS was significantly longer with acalabrutinib monotherapy (not reached) compared to the best investigator's choice (16.5 months,  $p < 0.0001$ ). The estimated 12-month PFS was 88% for acalabrutinib and 68% for investigator's choice [56]. In the ELEVATE-TN study, acalabrutinib or acalabrutinib in combination with obinutuzumab was used in the first-line of CLL patients aged  $\geq 65$  with a creatinine clearance between 30 and 69 mL/min or co-morbidities [Cumulative Illness Rating Scale (CIRS) score  $> 6$ ]. A control group received obinutuzumab and chlorambucil. Median PFS was significantly longer in patients treated with acalabrutinib-based regimens (not achieved vs. 22.6 months,  $p < 0.001$ ). The estimated 2-year PFS rate was 93%, 87%, and 43%, respectively [57]. The treatment was well tolerated. Most adverse reactions observed in clinical trials were grade 1–2. The most common adverse effects of acalabrutinib are headache, diarrhea, fatigue, nausea, and bleeding complications. The most common grade 4 adverse reactions are neutropenia, anemia, pneumonia, and thrombocytopenia. A phase III randomized trial comparing acalabrutinib with ibrutinib in previously treated CLL patients showed similar efficacy of both drugs. Acalabrutinib was, however, better tolerated.

Advanced phase III trials are also being performed with other BTK inhibitors, including zanubrutinib, which is already approved by the Food and Drug Administration (FDA) for the treatment of mantle cell lymphoma (MCL) and in patients with recurrent CLL in China.

Idelalisib, a PI3K inhibitor, according to the current EMA approval, is recommended in combination with rituximab in the first-line of CLL treatment in patients with del17p/*TP53* mutation who

cannot receive alternative treatment as well as in relapsed/refractory CLL. Idelalisib in combination with rituximab compared to rituximab monotherapy significantly extended the median PFS, from 7.3 months to 19.4 months (HR 0.25;  $p < 0.0001$ ). The median OS in the idelalisib group was not reached, and in the placebo group it was 20.8 months (HR 0.34;  $p = 0.0001$ ) [58]. Due to the increased risk of serious infections and deaths due to infections observed in phase III clinical trials in patients treated with first-line idelalisib in combination with chemotherapy, mainly CMV and *Pneumocystis jirovecii*, SmPC infection risk mitigation measures should be applied in all patients [59]. Further studies of other PI3K inhibitors are ongoing. Develisib has been registered in the treatment of relapsed patients based on phase III studies, and studies on umbralisib in combination with ublituximab (anti-CD20 antibody) are very advanced [60].

### **BCL2 antagonists**

Venetoclax is an oral, selective inhibitor of BCL2, the only drug in this group approved for the treatment of CLL. The current indication, according to the EMA, is first-line treatment in monotherapy or in combination with obinutuzumab and for the treatment of relapsed/refractory CLL either alone or in combination with rituximab. Venetoclax alone enables 79% response rates in relapsed CLL [61]. Complete remissions were observed in 20% of patients, and in 5% very deep responses with negative MRD. Venetoclax in monotherapy is used continuously, while in combination with monoclonal antibodies, the therapy is carried out for a limited time only. A venetoclax and rituximab (VenR) regimen was approved based on the results of the MURANO phase III clinical trial, in which venetoclax was administered together with rituximab (six doses) for two years, and the efficacy was compared to bendamustine and rituximab. The reduction in the risk of progression was 81% and the risk of death was 60% in patients treated with VenR compared to BR [32]. The median time to progression and time to the next treatment were 53.6 and 57.8 months in patients receiving venetoclax plus rituximab, and 17 and 23.9 months in the BR arm, respectively (Table 4) [32]. Residual disease eradication was achieved in as many as 63.8% of patients treated with VenR. The update of the results of the MURANO study after five years of follow-up, presented at the American Society of Hematology (ASH) meeting in 2020, showed that the benefits were maintained for PFS (57.3% and 4.6%) and OS (85.3% vs. 66.8%), despite using new

**Table 5.** Tumor lysis syndrome risk assessment and pre-treatment prophylaxis

Tumor lysis syndrome risk assessment		
Low risk	Medium risk	High risk*
Enlarged lymph nodes < 5 cm and leukocytosis < 25 G/L	Lymph nodes > 5 cm and < 10 cm or leukocytosis > 25 G/L	Lymph nodes > 10 cm (in imaging) or leukocytosis > 25 G/L and lymph nodes > 5 cm and < 10 cm (in imaging)
Prophylaxis of tumor lysis syndrome		
Allopurinol 300–600 mg orally from 72 h before starting treatment Hydration 1.5 L orally from 48 h prior to treatment	Allopurinol 300–600 mg orally from 72 hours before starting treatment Hydration 2–3 L orally from 24 h before start of treatment and intravenously during hospitalization	Allopurinol 300–600 mg orally from 72 h before starting treatment Hydration 2–3 L orally from 24 h before start of treatment and intravenously during hospitalization Rasburicase 0.05–0.2 mg/kg (depending on local procedures, necessary in patients with uric acid level > 8.0 mg/dL)

\*An additional risk factor for tumor lysis syndrome is renal failure with creatinine clearance <80 mL/min

**Table 6.** Cairo-Bishop definition of laboratory tumor lysis syndrome

Parameter	Value	Change after treatment
Uric acid	> 8 mg/dL	> 25%
Potassium	< 6 mg/dL	> 25%
Inorganic phosphates	> 1.45 mmol/L	> 25%
Calcium	< 1.75 mmol/L	> 25%

targeted therapies in patients treated according to the BR regimen in subsequent lines of treatment. Particularly long responses were observed in patients who achieved MRD negativity after completing a VenR regimen [33].

Earlier studies have proven the efficacy of venetoclax monotherapy in CLL patients with del17p. For all patients, the objective response rate was 77% and the estimated progression-free survival at month 24 was 54% (95% CI, 45% to 62%). For 16 patients who had previously received kinase inhibitors, the objective response rate was 63% (10/16 patients) and the estimated 24-month PFS was 50% (95% CI, 25% to 71%) [62].

The efficacy of venetoclax was assessed in patients receiving ibrutinib in the previous therapy. In total, 59/91 (65%) patients responded to treatment with venetoclax [63].

In the CLL14 study, venetoclax in combination with obinutuzumab was used in the first-line treatment in patients with comorbidities. Obinutuzumab in combination with chlorambucil was administered in the control arm. Treatment duration for both regimens was 12 months. At 24 months after randomiza-

tion, PFS rate was significantly higher in patients treated with the venetoclax-containing regimen (88.2% vs. 64.1%) (Table 4). A benefit in terms of PFS was also observed in patients with del17p and unmutated *IGVH* [19]. The update of the CLL14 study 48 months after randomization presented at the ASH 2020 meeting demonstrated persistent PFS benefits (74 vs. 35.4%), with a 67% reduction in the risk of progression or death compared to patients treated with chlorambucil and obinutuzumab. Treatment with venetoclax and obinutuzumab was associated with a high MRD eradication rate, which correlated with longer PFS [64]. In ongoing clinical trials, venetoclax is used in combination with the BTK inhibitors, ibrutinib, and acalabrutinib.

The most common side effects of venetoclax are neutropenia, diarrhea, nausea, anemia, upper respiratory tract infection, thrombocytopenia, and fatigue. Serious complications can include pneumonia, febrile neutropenia, hemolytic anemia, and metabolic disturbances associated with tumor lysis syndrome. All patients should be assessed for the risk of tumor lysis, and appropriate prophylaxis and management in the event of laboratory or clinical symptoms of tumor lysis syndrome (TLS) should be administered (Tables 5 and 6) [65]. The regimens used in the treatment of CLL and the results of the phase III clinical trials for current regimens are set out in Tables 3 and 4.

### Cellular immunotherapy Allogeneic hematopoietic stem cell transplantation

Allogeneic hematopoietic stem cell transplantation (allo-HSCT) remains the only method that

can cure CLL. However, because of the serious complications associated with this procedure, it is only recommended for high-risk patients. The introduction of new drugs has changed the site of allogeneic transplantation in the treatment of CLL. Currently, allo-HSCT is indicated in high-risk disease and after treatment failure with at least one BCR pathway inhibitor or a BCL2 antagonist [66, 67]. The decision should be made on an individual basis, and patients with high-risk disease after novel BCR and BCL2 inhibitors failure should be carefully analyzed for alternative treatment options, risk of Richter transformation, complications, or transplant failure. A phase II study by a German group showed a 65% 4-year survival rate, with no differences in the presence of negative cytogenetic prognosis or in patients refractory to previous treatment [68]. Similar results were obtained by other transplant groups, indicating a *plateau* of survival curves at a 40–50% level. Reduced-intensity conditioning protocols used by an American group resulted in 3-year survival in 59% of patients [69]. Long-term European Society for Blood and Marrow Transplantation (EBMT) analyses showed 28%, 35%, and 40% 10-year event-free survival (EFS), OS, and non-relapse mortality (NRM) after allo-HSCT, respectively [70].

### **CAR-T therapy**

The use of chimeric antigen receptor (CAR) T cells is currently the most promising and dynamically developing cell therapy modality. Numerous CAR-T constructs are currently being evaluated in clinical trials of various stages of advancement, showing promising results in terms of therapeutic efficacy. In one long-term follow-up study, median PFS was 40.2 months in patients who achieved CR and did not reach median OS [71]. The addition of ibrutinib resulted in improved CAR-T efficacy in CLL patients.

### **First-line treatment**

Currently there are three treatment strategies employed in first-line settings: time-limited immunochemotherapy with anti-CD20 monoclonal antibodies, continuous administration of targeted drugs (ibrutinib, acalabrutinib, venetoclax), and time-limited chemotherapy-free regimens (venetoclax and obinutuzumab).

### **Factors influencing choice of first-line treatment**

The following factors should be considered when choosing the first-line therapy:

- performance status [Eastern Cooperative Oncology Group (ECOG), Karnofsky scales];
- concomitant diseases;
- vital organs assessment (including creatinine clearance);
- chronological and biological age;
- susceptibility to infections;
- prognostic factors (del17p/*TP53* mutation, *IGVH* mutation status);
- availability of drugs.

CIRS is the most widely used tool to assess comorbidities (Table 7). It involves the evaluation of 14 organs/systems using a 5-point score, where zero points signifies disease-free/normal organ function and four points signify a life-threatening condition [72, 73]. When choosing a therapeutic option, the patient's preferences should also be considered, after a detailed presentation of the potential benefits and side effects, the route of administration, and the need for hospitalization related to the given treatment method.

The presence of del17p/*TP53* mutation, correlated with resistance to alkylating drugs and purine analogs, is an important factor influencing the choice of therapeutic regimen. According to the current recommendations of international scientific societies, before starting first-line treatment, *IGVH* mutation status should also be assessed, because the lack of mutation is associated with a short duration of response to immunochemotherapy. When choosing between a time-limited treatment (venetoclax and obinutuzumab) and the continuous administration of BTK inhibitors, the following factors should be considered: toxicity profile (renal function and risk of TLS vs. atrial fibrillation and risk of bleeding), the administration route [intravenous (i.v.) + oral vs. only oral], and the frequency of follow-up visits (5-week period of increasing the dose of venetoclax) [8].

### **Patients without del17p/*TP53* mutation and with mutated *IGVH***

#### **Patients in good general condition without significant comorbidities**

In patients in good general condition, without significant comorbidities and with normal renal function, the recommended regimen is FCR or CCR immunochemotherapy (Figure 1) [8]. According to the research conducted by the German CLL Study Group (GCLLSG), intensive immunochemotherapy can be used in patients who meet the following criteria:

- CIRS score  $\leq 6$  and;
- creatinine clearance  $\geq 70$  mL/min [74].

**Table 7.** Evaluation of comorbidities using Cumulative Illness Rating Scale scale

Score	Degree of dysfunction	Description
0	None	No organ (system) health problem or past medical problem with no clinical sequelae
1	Mild	Current health problem that does not require or periodically requires treatment (e.g. hernia, hemorrhoids, asthma treated periodically with bronchodilators, heartburn treated periodically with antacids) or significant medical problems in past (e.g. kidney stones), including those treated with surgery (hysterectomy, cholecystectomy), good prognosis, normal activity
2	Moderate	Disease (functional disorder) requiring constant medication (first-line treatment), good prognosis, slightly limited activity (e.g. asthma treated with inhaled corticosteroids, gastroesophageal reflux disease or osteoarthritis requiring daily medication)
3	Severe	Chronic disease, ineffective first-line treatment, uncertain prognosis, significant limitation of activity (e.g. symptoms of angina despite treatment, circulatory failure and/or uncontrolled hypertension despite combination therapy)
4	Very severe	Emergency requiring immediate treatment or hospitalization, poor prognosis (e.g. unstable angina, myocardial infarction, stroke, urinary tract obstruction, gastrointestinal bleeding) or severe organ failure (renal failure requiring dialysis, chronic obstructive pulmonary disease requiring oxygen therapy), severe damage to sense organs (almost complete blindness or deafness)
Organ/system	Disease/dysfunction	Score
Heart		
Hypertension		
Vascular		
Respiratory		
Eyes/nose/ears/throat		
Digestive tract — upper section		
Digestive tract — lower section		
Liver		
Kidneys		
Urogenital		
Bone-muscular		
Endocrine/metabolic		
Neurological		
Mental		
<b>Total:</b>		

According to the current ESMO recommendations, rituximab and bendamustine should be used in patients aged > 65 and/or with a history of recurrent infections [8]. Alternatively, ibrutinib or venetoclax and obinutuzumab may be administered.

**Patients with comorbidities, not eligible for intensive immunochemotherapy**

In patients not eligible for intensive immunochemotherapy, the currently recommended treatment standards (ESMO, NCCN) are venetoclax in combination with obinutuzumab, chlorambucil with obinutuzumab, ibrutinib or acalabrutinib [8, 75]. In Poland, currently only obinutuzumab

and chlorambucil regimens are reimbursed under the drug program.

In patients of very advanced age, in poor general condition, in whom intravenous drugs cannot be used, monotherapy with chlorambucil or cyclophosphamide can be used.

**Patients without del17p/TP53 mutation and with unmutated IGVH**

**Patients in good general condition without significant comorbidities**

The recommended therapy for this group of patients is BTK inhibitors (ibrutinib, acalabrutinib). Alternatively, venetoclax in combination with obinutuzumab can be used. Chemoimmunotherapy is not

recommended due to poor survival rates, but may be used if novel targeted therapies are not available.

#### Patients in poor general condition with comorbidities

According to the ESMO recommendations, the optimal treatment regimens for this group of patients include venetoclax with obinutuzumab, ibrutinib or acalabrutinib. Alternatively, obinutuzumab in combination with chlorambucil can be administered.

In Poland, currently except immunochemotherapy the only targeted therapy is venetoclax and obinutuzumab reimbursed in patients that are not qualified to intensive therapy is available for this group of patients (as part of the drug program and the chemotherapy catalog, respectively).

#### Patients with del17p/*TP53* mutation

Patients with del17p/*TP53* mutation should not be treated with immunochemotherapy [8, 75]. BCR and BCL2 inhibitors are currently considered the most effective conventional regimens in patients with del17p/*TP53* mutation. The recommended first-line treatment regimens (ESMO, NCCN) include ibrutinib, acalabrutinib, venetoclax and obinutuzumab or venetoclax in monotherapy. Idelalisib, according to the ESMO recommendation, can be used in the first-line of CLL treatment in patients with del17p/*TP53* mutation who are ineligible for alternative treatments, and it is necessary to adhere to the recommendations to reduce the risk of infectious complications [8]. Currently (June 2021) in Poland none of the new targeted therapies is reimbursed in the first-line treatment of CLL patients with del17p/*TP53* mutation. In the absence of BCR and BCL2 inhibitors, other options include alemtuzumab in combination with corticosteroids and rituximab in combination with high doses of corticosteroids (methylprednisolone) [75]. The current recommendations for selecting the first-line therapy are set out in Figure 2.

#### Treatment of relapsed/refractory CLL

The indications for the initiation of second and subsequent lines of treatment are the same as for first-line treatment. Similar to the initiation of first-line treatment, also in relapsed patients, adverse biological features (LDH,  $\beta_2$ -microglobulin, chromosomal aberrations) are not an indication to start treatment if the patient does not meet the above-mentioned criteria for CLL progression. In second and subsequent lines of treatment, the therapeutic decision depends on the duration of remission, the type of prior treatment, the presence of del17p/*TP53*

mutation, general condition, comorbidities, patient preferences, and the availability of drugs.

According to the recommendations of international scientific societies, the optimal method of treating patients with relapsed/refractory CLL are novel targeted therapies, namely, BCR and BCL2 inhibitors [8, 75].

First-line treatment may be repeated if no relapse has been observed for three years after the completion of previous treatment. The BR regimen should be the preferred regimen of immunochemotherapy in relapsed patients, also those previously treated with FCR or CCR. Some analyses show comparable efficacy of BR in the first relapse compared to novel therapies [76]. Repeated administration of FCR regimen is not recommended due to increased toxicity and the risk of secondary hematopoietic malignancies. Obinutuzumab in combination with chlorambucil is approved for the treatment of first-line CLL only, hence it is not possible to repeat the therapy.

For symptomatic recurrence within three years after previous time-limited therapy, the treatment regimen should be changed, regardless of the type of treatment used. According to the ESMO recommendations, one of two treatment options should be used:

- 1) either venetoclax + rituximab (24 months);
- 2) or BTK inhibitors (as continuous therapy).

Alternatively, idelalisib in combination with rituximab (continuous therapy) can be administered. Immunochemotherapy can be used in patients without del17p/*TP53* mutation if no other treatment options are available.

In patients with del17p or *TP53* mutation, regardless of the response duration after the first-line therapy, novel targeted therapies should be used:

- BTK inhibitors (ibrutinib, acalabrutinib);
- venetoclax in combination with rituximab or in monotherapy;
- idelalisib with rituximab.

In Poland today (November 2021), novel targeted therapies are available as part of the drug programs described below.

Ibrutinib can be used as part of a drug program in patients with relapsed/refractory CLL with del17p and/or *TP53* mutation and in patients with relapsed/refractory CLL who meet one of the following criteria:

- relapse/progression or lack of response to venetoclax in combination with anti-CD20 antibody;
- medical contraindications for venetoclax in combination with anti-CD20 antibody (in

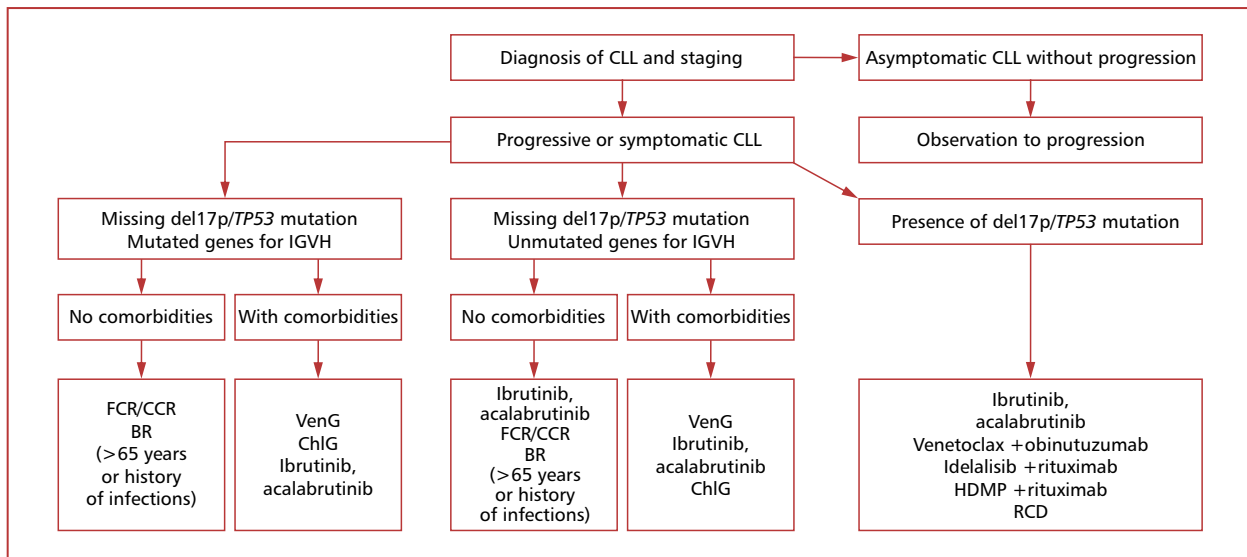

**Figure 2.** Recommendations for first-line treatment of patients with chronic lymphocytic leukemia (CLL); IGVH — immunoglobulin variable heavy chain; FCR — rituximab, fludarabine, cyclophosphamide; CCR — cladribine, cyclophosphamide, rituximab, BR — bendamustine, rituximab; VenG — venetoclax, obinutuzumab; ChIG — chlorambucil, obinutuzumab; HDMP — high-dose methylprednisolone; RCD — rituximab, cyclophosphamide, dexamethasone

accordance with the SmPC or B103 drug program, Part I) in patients with early relapse of CLL after first-line immunochemotherapy (defined as CLL progression 6–24 months after completion of prior treatment) or in patients with resistance to immunochemotherapy (defined as no response or recurrence of CLL up to six months after completion of prior treatment);

- toxicity preventing continuation of treatment with venetoclax and anti-CD20 antibody.

Venetoclax with rituximab is reimbursed in patients after one line of previous therapy regardless of del17p/TP53 mutation status.

In previously treated patients, regimens containing alemtuzumab can also be used. However, the current availability of this drug is limited to cases when the drug is donated by the manufacturer. Due to the policy of the manufacturer, this is an ‘off-label’ indication.

Currently, the importance of R-CHOP (rituximab, cyclophosphamide, doxorubicin, vincristine, prednisone) immunochemotherapy is limited in the treatment of CLL patients. The only certain indication is the transformation into diffuse large B-cell lymphoma [diffuse large B-cell lymphoma (DLBCL), Richter transformation]. In other indications, no benefit has been shown from this form of treatment, indicating limited efficacy with relatively high toxicity [77]. The German GSGCLL group study determined the effec-

tiveness of R-CHOP therapy in patients with high-risk CLL, with autoimmune cytopenias, and in Richter transformation. Despite 54–74% OR, median PFS was surprisingly short at 9–10 months. Due to toxicity, including hematological complications observed in 92% of patients and severe infectious complications in 28%, treatment was discontinued in 45% of patients. Therefore, the R-CHOP regimen is not recommended for the treatment of patients with CLL in cases other than Richter transformation. The RCD regimen (rituximab, cyclophosphamide, dexamethasone) should be used in the treatment of autoimmune cytopenias.

The introduction of BCR inhibitors and BCL2 antagonists has significantly changed the treatment options in patients with relapsed/refractory CLL and changed the indications for allo-HSCT, which is now recommended in the following clinical situations:

- resistance to immunochemotherapy in patients with del17p/TP53 mutation with good response to novel targeted therapies. Allo-HSCT should be discussed as a treatment option for CLL if peri-transplant risk is low;
- resistance to immunochemotherapy and new targeted therapies, even with a higher risk of mortality associated with transplant procedure [HCT-CI (Hematopoietic Cell Transplantation — Comorbidity Index) ratio ≥ 3];



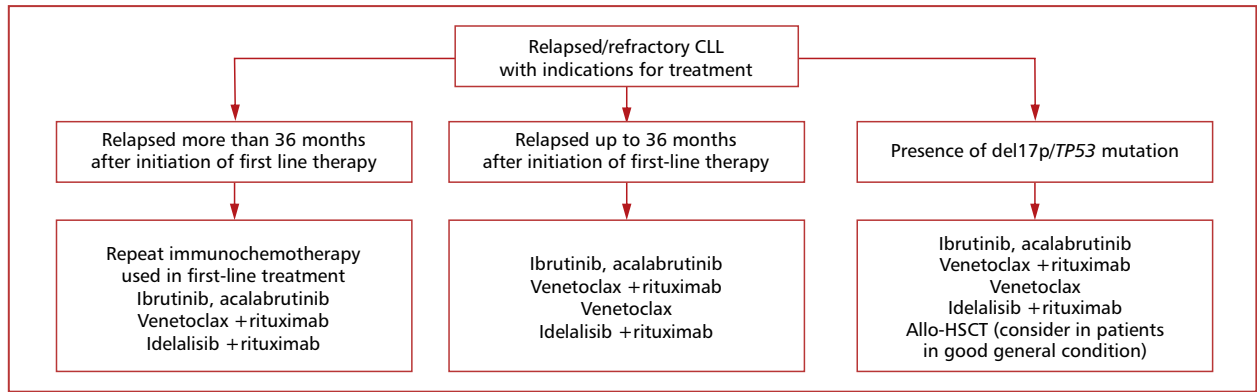

**Figure 3.** Recommendations for the treatment of patients with refractory or relapsed chronic lymphocytic leukemia (CLL, chronic lymphocytic leukemia); allo-HSCT — allogeneic hematopoietic stem cell transplantation

- Richter transformation clonally related to CLL in remission after pharmacological treatment [8].

To summarize the available treatment options in the treatment of subsequent lines, the use of BCR and BCL2 inhibitors (in combination with rituximab or in monotherapy) should be considered where available. In patients without increased risk factors (genetic or clinical), immunochemotherapy regimens (most often BR or rituximab in combination with chlorambucil) or rituximab in combination with high doses of glucocorticosteroids (methylprednisolone, dexamethasone) can be used. Due to the limited effectiveness of the existing therapeutic regimens, patients with refractory CLL should be qualified for clinical trials of novel drugs. In selected patients with a particularly poor prognosis, resistance to immunochemotherapy and/or targeted therapy, allogeneic hematopoietic stem cell transplantation should be considered. The current recommendations regarding the choice of therapy in patients with refractory or recurrent CLL are set out in Figure 3.

### Richter transformation

Richter transformation (Richter syndrome) is one of the most serious complications of CLL. It is defined as the occurrence of secondary aggressive B-cell lymphoma in a patient diagnosed with CLL [78]. The most common histological subtype, comprising c.80–95% of all cases, is DLBCL [79]. The second, much less common, form is the transformation to classical Hodgkin lymphoma, often referred to as the Hodgkin variant of Richter transformation (HvRT) [80]. HvRT affects approximately 5–15% of all Richter syndrome cases.

Contrary to popular belief, Richter's syndrome is not a very rare or a late complication. Based on

many observational studies, it has been established that it occurs in up to 5–15% of CLL patients. The median time from diagnosis of CLL to onset of Richter's syndrome is 2–4 years, and in rare cases both cancers are diagnosed simultaneously [79]. It should be emphasized that the percentage of patients with Richter's syndrome significantly depends on the frequency of surgical lymph node biopsy in patients with rapid progression of CLL [81]. A more aggressive biopsy strategy should be considered, especially in patients with risk factors for Richter transformation (Table 8).

The pathomechanism of Richter transformation is not completely understood, although molecular mechanisms underlying CLL transformation are well understood [82–84]. In molecular analyses of a series of patients with Richter's syndrome, a high frequency of defects in genes directly or indirectly involved in cell cycle regulation, including *TP53*, *NOTCH1*, and *CDKN2A/B*, was observed [85]. Two types of transformation have been distinguished, characterized by differing clinical courses. In the first type, Richter's syndrome results from clonal evolution of CLL (the so-called Richter's syndrome 'clonally related to CLL'), while in the second group, the aggressive lymphoma originates from a different lymphocytic clone (Richter's syndrome 'not clonally related to CLL'). Richter's syndrome clonally associated with CLL is much more common (80–90% transformation to DLBCL and approximately 40–60% of HvRT), and has a very poor prognosis [82]. On the other hand, Richter's syndrome that is clonally independent of CLL is less common, but the prognosis is similar to that of DLBCL and HL *de novo*. One study has shown that the median survival time in patients with Richter's syndrome clonally associated with

**Table 8.** Risk factors associated with Richter's syndrome in course of chronic lymphocytic leukemia

<b>Patient dependent factors</b>
<i>CD38</i> gene polymorphism
<i>LPR-4</i> gene polymorphism
<i>BCL2</i> gene polymorphism
Age (controversial)
<b>Environmental factors</b>
EBV reactivation (controversial)
Treatment with purine analogs (controversial)
<b>Factors associated with leukemia biology</b>
Karyotype (lack of del13q14)
Lack of <i>IGHV</i> mutation
Stereotyped BCR
Short telomeres
High expression of CD38
<b>Clinical factors</b>
Lymphadenopathy >3 cm
Rai III/IV
<small>EBV — Epstein-Barr virus; BCR — B-cell receptor</small>

CLL was only 14 months, compared with 62 months in patients with Richter's syndrome not clonally related to CLL [84].

Clinically, Richter's syndrome is usually characterized by deterioration of general condition, often with the occurrence of systemic symptoms (weight loss, fever, night sweats) and rapidly progressive local or generalized lymphadenopathy or, less frequently, extra-nodal lesions [79]. In order to diagnose Richter's syndrome, histopathological evaluation of a surgical biopsy of a lymph node or the affected extra-nodal organ is required. Histopathological diagnosis is of key importance for the differentiation of Richter's syndrome from similar clinical conditions, i.e. CLL progression and prolymphocytic transformation. It is recommended to perform the biopsy of the node with the largest diameter or the fastest growing one. A PET/CT scan may be of significant help; in this case, the most metabolically active node should be sampled [86]. In exceptional cases, if a surgical biopsy of the node is impossible, the diagnosis can also be made by an experienced diagnostician based on a cytological examination with cytometric immunophenotyping. When Richter's syndrome is diagnosed, standard staging tests should be performed, as in primary DLBCL and HL. However, the staging is difficult because it is impossible to distinguish nodal and organ changes resulting from Richter's syndrome and CLL in diagnostic imaging.

Richter's syndrome is most often characterized by an aggressive course, resistance to treatment, and short survival [79]. In the first-line treatment of patients with the DLBCL variant of Richter transformation, R-CHOP is most often used, although the effectiveness of this regimen is unsatisfactory [85]. The use of stronger chemotherapy regimens allows for an increase in the response rate and depth, but is associated with significantly greater toxicity and generally does not improve the prognosis. In phase II studies, intensive OFAR-1, OFAR-2, R-hyper-CVAD (rituximab, cyclophosphamide, vincristine, doxorubicin, dexamethasone), and DA-EPOCH-R (etoposide, prednisone, vincristine, cyclophosphamide, doxorubicin, rituximab) regimens allowed for the achievement of CR in 39–51% of patients, but the median survival was only 6–10 months [87, 88]. New targeted therapies, which spectacularly improved the prognosis in relapsed/refractory CLL, did not show high efficacy in this patient group. In clinical trials with small groups of patients, short-term responses were mainly observed in patients treated with BTK inhibitors (ibrutinib, acalabrutinib), PI3K (idelalisib), and BCL2 (venetoclax). So far, the most promising results have been observed for combinations of ibrutinib with programmed death receptor 1/programmed death-ligand 1 (PD-1/PD-L1) checkpoint inhibitors (nivolumab, pembrolizumab), but this observation requires confirmation in larger studies [89–91].

Because the low frequency of Richter transformation makes it impossible to conduct randomized trials, no standard of treatment has yet been developed. Moreover, due to the advanced age and poor performance status of most of these patients, in clinical practice it is often necessary to reduce the intensity of chemotherapy. Currently, in any new diagnosis of Richter transformation, it is recommended to establish a clonal relationship with CLL by comparing the CLL immunoglobulin gene rearrangement in the cells to the areas infiltrated by the aggressive lymphoma with CLL cells. In patients with Richter transformation not clonally related to CLL (c.20% of patients), treatment should be carried out in accordance with *de novo* DLBCL treatment standard. In Richter transformation clonally associated with CLL, or in cases when clonal dependence cannot be established, there is no effective treatment, and participation in a clinical trial should be the first choice. If this is impossible, immunochemotherapy with anti-CD20 antibody should be used, although the R-CHOP regimen still seems a rational choice. Due to the expected short

response time, in all patients who have achieved at least a partial response to chemotherapy and who are in a good clinical condition and of an appropriate age, the next step should be consolidation of the response with high-dose chemotherapy followed by hematopoietic stem cell transplantation (HSCT) [91]. The preferred method of consolidation, especially in younger patients, is allo-HSCT, but auto-HSCT may also improve prognosis in some patients [92]. It should be emphasized that due to the clinical context, allo-HSCT can be performed only in c.10–15% of patients diagnosed with Richter transformation [93].

In patients with HvRT, ABVD (adriamycin, bleomycin, vinblastine, dacarbazine) regimen is the most commonly administered. The treatment results in HvRT are better than in clonally dependent DLBCL variant, but worse than in *de novo* HL [80, 81]. Therefore, if the patient is not eligible for a clinical trial, the ABVD regimen is recommended. The role of consolidation using HSCT in this type of transformation is not yet established.

Treatment of refractory and relapsed disease is not standardized and is mainly based on combination chemotherapy used in aggressive lymphomas. Treatment outcomes are mostly unfavorable. Therefore, participation in a clinical trial should always be the preferred option. The prognosis of patients with Richter transformation is poor. In most published reports, the median survival in patients with DLBCL variant of Richter transformation was 6–18 months after the transformation [85, 93]. Patients with untreated CLL and Richter transformation have a longer life expectancy than patients previously treated with chemotherapy for CLL [94]. Most reports indicate that the prognosis in HvRT is better than in patients with classic transformation to DLBCL, although the available data on this subject is inconclusive [80, 81]. A simple prognostic system based on basic clinical and laboratory parameters has been developed to assess the prognosis of Richter transformation in more detail (*see* Table 9) [93].

### Diagnosis and treatment of autoimmune complications

Autoimmune complications in patients with CLL are the result of immune system disorders that lead to the production of antibodies against autoantigens, most often localized on blood cells or their precursors. This leads to autoimmune cytopenia, primarily for autoimmune hemolytic anemia (AIHA), and autoimmune thrombocytopenia (IT).

**Table 9.** Richter syndrome risk score (adapted from [94])

Parameters with independent negative predictive value for survival	
ECOG performance status > 1	
LDH > 1.5 upper limit of normal	
PLT < 100 G/L	
Largest node or non-nodal lesion > 5 cm	
Number of previous lines of therapy > 1	
Prognostic index	
Score	Estimated survival time
0–1	13 months
2	11 months
3	4 months
4–5	1 month

ECOG — Eastern Cooperative Oncology Group; LDH — lactate dehydrogenase; PLT — platelets

The co-occurrence of AIHA and IT is called Evans syndrome.

AIHA is the most common autoimmune cytopenia reported in CLL patients. Its incidence is estimated at 5–10%. It is caused by warm IgG autoantibodies, detected by a direct antiglobulin test (DAT) [95, 96]. A positive DAT is the most important risk factor for the development of AIHA, although not all DAT-positive patients develop AIHA. Similarly, a negative DAT result does not exclude the risk of AIHA in the future (positive predictive value c.30%, negative predictive value c.90%) [97].

Autoimmune cytopenias may also occur during cytoreductive therapy. In particular, it has been observed that treatment with purine analogs in monotherapy may increase the risk of AIHA [98–101]. The incidence of autoimmune cytopenia during treatment with ibrutinib or venetoclax alone and in combination with rituximab is low and, in most studies, does not exceed 5% [32, 102–105].

The diagnosis of AIHA is based on laboratory signs of hemolysis (increased free bilirubin and increased LDH activity, decreased haptoglobin, and increased reticulocyte counts). However, it should be remembered that each of these indicators has significant limitations of specificity and sensitivity. Increased reticulocyte count may not be observed in cases with suppressed red blood cell production in the bone marrow. Elevated LDH activity may also result from progression of the primary disease, while indirect hyperbilirubinemia requires differentiation from Gilbert's syndrome. DAT, which detects IgG immunoglobulins and/

/or the C3 complement component, is an important diagnostic assay that is found positive in over 90% of patients with AIHA [96].

AIHA treatment is based on glucocorticosteroids, most often prednisone or prednisolone alone or in combination with rituximab at a dose of 1 mg/kg, increased to 1.5 mg/kg in the absence of response. Treatment with prednisone is effective in most patients, and in these cases it is recommended to maintain the therapeutic dose of corticosteroid for 2–6 weeks and then gradually discontinue treatment over a period of three months. To obtain a faster response to the treatment, a single administration of 1.0 g methylprednisolone or intravenous immunoglobulins in the dose of 0.4 g/kg bw/day for 4–5 days can be administered. There is no generally accepted standard of second-line treatment in patients not responding to prednisone treatment or with recurrent hemolysis at the attempt to discontinue treatment. In such cases, four-weekly administrations of rituximab at a dose of 375 mg/m<sup>2</sup> (if not administered in the first-line of therapy), cyclosporine 5–8 mg/kg bw/day to achieve a serum concentration of 100–150 ng/mL or mycophenolate mofetil are suggested. Oral cyclophosphamide or azathioprine may also be used [106–108]. Pharmacotherapy failure is an indication for splenectomy. Dearden [106] proposed an algorithm for the management of patients not responding to corticosteroid therapy, or with recurrent hemolysis after dose reduction. If two-week dosing of 1.5 mg/kg prednisone is ineffective, rituximab 375 mg/m<sup>2</sup> should be used, and maintenance therapy with cyclosporine or mycophenolate mofetil should be used after obtaining the response. However, if rituximab is not effective, splenectomy should be suggested. Recurrence of hemolysis while reducing the dose of prednisone can be controlled by adding cyclosporine at 5–8 mg/kg/day. The response time is up to six weeks. After obtaining the response, maintenance therapy with cyclosporine or mycophenolate mofetil, or the administration of rituximab followed by splenectomy, should be considered. Maintenance treatment with cyclosporine or mycophenolate mofetil is also recommended after splenectomy [106]. To maintain the response, the dose of cyclosporin may be reduced to 3 mg/kg bw/day, so that its serum concentration does not exceed 100 µg/L. Both cyclosporine and mycophenolate mofetil can be administered in long-term maintenance. However, while on cyclosporine, patients should be monitored for adverse effects, especially nephrotoxicity and hypertension.

An autoimmune hemolytic syndrome unresponsive to, or poorly controlled by, immunosuppressive therapy is an indication for cytoreductive therapy. Those regimens with increased immunosuppressive potential developed for other lymphoproliferative diseases are preferred. The most common is RCD (rituximab 375 mg/m<sup>2</sup> i.v. day 1, cyclophosphamide 750 mg/m<sup>2</sup> day 2, dexamethasone 12 mg i.v. days 1 and 2 and next orally on days 3–7, cycles repeated every 3–4 weeks) or R-COP (cyclophosphamide 750 mg/m<sup>2</sup>, vincristine 1.4 mg/m<sup>2</sup>, maximum 2 mg, rituximab 375 mg/m<sup>2</sup> on day 1, prednisone 40 mg/m<sup>2</sup> on days 1–5, every 21 days) [109, 110]. Treatment with purine analogs may increase the risk of AIHA, especially when used in monotherapy [36]. However, cases of hemolysis and/or DAT negatization have been reported during treatment with purine analog-containing regimens [111]. The combination of bendamustine and rituximab is also very effective [97, 112]. Treatment with ibrutinib or idelalisib may have a beneficial effect on the course of autoimmune cytopenia [102–104, 113]. Single reports also suggest that venetoclax may have a similar effect [114].

Immunothrombocytopenia is observed less frequently than AIHA, with an incidence of c.1–5% [115–118]. It should be considered in every case of a sudden drop in platelet counts not justified by other reasons, especially disease progression or treatment. A diagnosis of immunothrombocytopenia should be suspected in cases of rapid (less than two weeks) and significant (< 100 G/L and/or at least half the baseline value) reduction in platelet count, normal or increased marrow megakaryopoiesis, and the absence of splenomegaly in patients who did not obtain any cytostatic treatment in the previous month [116]. Due to the lack of sufficiently sensitive tests to detect antiplatelet antibodies, in clinical practice the diagnosis of IT is most often a diagnosis by exclusion.

The goal of treating immunothrombocytopenia is to maintain the platelet count above the hemostatic safety threshold, i.e. above 20–30 G/L. The treatment is similar to that of AIHA and essential immunothrombocytopenia. The basis of the first-line treatment is corticosteroid therapy, including prednisone 1 mg/kg bw, dexamethasone 40 mg/day for 4 days every 2–3 weeks, or methylprednisolone 1 g in a single dose. In cases of resistance or recurrence after reduction of corticosteroid dose, cyclosporine with prednisone, vincristine 1 mg weekly for 4–6 weeks, rituximab in monotherapy or RCD is suggested [106, 107, 119–121].

Another option is the use of thrombopoietin receptor agonists eltrombopag or romiplostin [122–124]. Failure of conservative treatment is an indication for splenectomy.

Pure red cell aplasia (PRCA) and autoimmune neutropenia are the rarest autoimmune complications observed in the course of CLL. These complications occur in < 1% of patients. Most often, in clinical practice this diagnosis is made by exclusion. It requires bone marrow biopsy, which in the case of PRCA shows atrophy of the red cell system with preserved granulopoiesis and thrombopoiesis, while in autoimmune neutropenia no precursors of granulopoiesis are found. In PRCA, hemoglobin  $\leq$  11 g/dL is found in the absence of hemolysis, absolute reticulocytopenia and a normal number of granulocytes and platelets. A viral background of aplasia should also be excluded. A diagnosis of autoimmune granulocytopenia should be considered in the presence of prolonged neutropenia < 0.5 G/L in a patient who has not received cytostatic treatment in the last eight weeks. There are no generally accepted rules for the management of these cytopenias. In the treatment of PRCA, in addition to transfusions of red blood cells, prednisone, cyclosporine, rituximab monotherapy or RCD are proposed [110, 120, 125, 126]. Prevention and treatment of infections are the baseline of immune neutropenia treatment.

It should be emphasized that isolated autoimmune cytopenia is not an indication for cytostatic treatment. However, AIHA or immunothrombocytopenia refractory to treatment, or accompanied by progression of the underlying disease, are considered indications for cytostatic treatment.

In the course of CLL, autoimmune processes in other organs can occur, which can be manifested both by the presence of autoantibodies, such as antinuclear antibodies or rheumatoid factor, and by the coexistence of autoimmune diseases [94]. The non-hematological autoimmune complications of CLL include paraneoplastic pemphigus, glomerulonephritis, and acquired angioedema. Due to its rarity, there is no established standard of care in these cases.

### Prevention and treatment of infections

Chronic lymphocytic leukemia (CLL) is a disease classified as a secondary immunodeficiency. The clinical picture in 50% of patients (regardless of the stage of CLL) is dominated by recurrent infections, often of severe course; death in more than one in three patients is associated with infection [127–130]. Infections in patients with CLL result not only from immunosuppression related to leu-

kemia itself, but also due to old age, comorbidities (e.g. diabetes, circulatory failure,) and anticancer treatment. The majority of infections are bacterial (67%), followed by viral (25%), and fungal (7%) [131–133]. In some patients infected with severe acute respiratory syndrome coronavirus 2 (SARS-CoV-2), immune deficiency observed in the course of CLL leads to impaired elimination of the virus from the body. Positive PCR and antigen tests may be observed for more than 8–12 weeks; recurrences of infection shortly after obtaining negative results of tests for SARS-CoV-2 infection are observed in many patients with CLL [134, 135, authors' observations].

### Prevention of infections

Prevention of infections and related complications is an important part of the treatment of patients with CLL. *Pneumocystis jirovecii* pneumonia prophylaxis is recommended in patients receiving treatment regimens containing fludarabine, cladribine, bendamustine or idelalisib. Cotrimoxazole is most often administered at 960 mg every other day during the treatment and for at least 3–6 months after the end of treatment with the above-mentioned drugs. *Pneumocystis jirovecii* infection prophylaxis is not required with BTK inhibitors and venetoclax. The prevention of viral infections *Herpes simplex* and *Herpes zoster* prophylaxis is recommended in patients treated with fludarabine, cladribine, bendamustine, alemtuzumab or anti-CD20 antibodies, especially patients with a history of recurrent infections with these viruses and with a low percentage/number (< 0.2 G/L) of CD4+ T-cells [130]. Prophylactic use of antiviral drugs such as acyclovir or valacyclovir should last 2–6 months after the end of chemotherapy or until CD4+ T cell count > 0.2 G/L is achieved, if possible. If serum anti-HBc antibodies and/or HBs antigen are present in a patient treated with anti-CD20 monoclonal antibodies, a PCR test for hepatitis B virus DNA should be performed. HBsAg positive patients with or without detectable hepatitis B virus (HBV) DNA, and HBsAg negative/anti-HBc positive patients should also start HBV reactivation prophylaxis with entecavir or tenofovir [130]. Screening and prophylaxis of reactivation of hepatitis B infection is also recommended in patients treated with ibrutinib [136, 137].

Antifungal prophylaxis with fluconazole, and in the case of suspected infection with *Aspergillus*, itraconazole, voriconazole, posaconazole, or caspofungin, is recommended in patients at high risk of infection, with low CD4+ T cell counts, receiving

purine analogs or alemtuzumab. Ibrutinib increases the risk of developing invasive mycosis (especially aspergillosis) and pneumocystosis (*Pneumocystis jirovecii*, PJP) in the first months of use (median three months) [138, 139]. Despite these findings, prophylactic use of antifungal agents is not recommended, although the concomitant use of ibrutinib and corticosteroids or other immunosuppressive treatments should be avoided.

### **Prophylactic and therapeutic use of immunoglobulins**

Prophylactic use of immunoglobulins in patients with CLL may reduce the incidence of bacterial infections, but has no effect on the incidence of viral and fungal infections or survival [140, 141]. Recurrent or severe infections, especially with encapsulated bacteria, despite prophylactic oral antibiotics in patients with serum IgG < 5 g/L, are an indication for intravenous or subcutaneous immunoglobulin replacement therapy (a procedure reimbursed by the Polish National Health Fund). Human immunoglobulin preparations can be administered intravenously every 3–4 weeks at an initial dose of 0.4 g/kg body weight or every two weeks by subcutaneous infusion [130]. Subcutaneous infusion preparations are better tolerated and very rarely cause the side effects such as fever, chills, and anaphylaxis often observed with intravenous preparations.

Ultimately, the aim of the treatment is IgG concentration of 6–8 g/L after four months of treatment [142]. The dose of immunoglobulin should be adjusted according to the clinical response and the antibody concentration achieved. Maintaining higher minimal levels may be beneficial in patients with concomitant chronic bronchial and pulmonary diseases [143, 144]. If a decision is made to discontinue human immunoglobulin replacement therapy, this should be done during the summer, and IgG levels should be checked before winter comes. Treatment should be discontinued if no reduction in the frequency or severity of bacterial infections is observed after 12 months [145]. Hypogammaglobulinemia does not significantly affect the clinical course of coronavirus disease 2019 (COVID-19) [144], although patients with CLL with low serum IgG levels may be more likely to develop secondary bacterial infections, which can result in sepsis and death [147, 148].

### **Prophylactic vaccinations**

It has been shown that one of the most important factors influencing the frequency and severity of infections in some CLL patients is, apart from

low total IgG concentration, low antibody titers against pneumococcal envelope polysaccharides [149]. This suggests that preventive vaccinations against *Streptococcus pneumoniae* may have a beneficial effect in this group of patients. Evaluation of the post-vaccination response in patients with CLL has revealed that this group shows a weaker response to immunization against pneumococci and influenza virus than healthy individuals [150–152]. Numerous studies have shown that immunization in patients with CLL is safe and some of them respond well, especially to *Streptococcus pneumoniae* and *Hemophilus influenzae* type B conjugate vaccines, administered immediately after diagnosis, at least two weeks before the initiation of therapy [152, 153]. Seasonal influenza vaccination in patients who have not responded to the first immunization should be administered in a two-dose schedule with a minimum monthly interval between vaccinations [154].

The vaccination schedule should be adapted to the planned treatment, with particular emphasis on anti-CD20 antibody therapy which depletes B lymphocytes and may cause hypogammaglobulinemia. It has been shown that protective levels of antibodies after influenza vaccination are not achieved in CLL patients when vaccination is given earlier than two weeks before, during and after chemoimmunotherapy, or up to six months after the end of rituximab treatment [152, 155]. If a patient has received unconjugated pneumococcal vaccine many years ago and levels of *Streptococcus pneumoniae* specific antibodies are low, it is recommended to re-vaccinate preferably prior to initiating human immunoglobulin replacement therapy.

### **Recommendations for preventive vaccinations**

Vaccination against *Streptococcus pneumoniae* and against *Hemophilus influenzae* type B is recommended immediately after diagnosis and before the initiation of treatment. Patients who, despite an initial response to vaccination, have decreased levels of specific antibodies leading to development of an infection should be immunized. Annual (September/October) vaccinations against seasonal influenza with vaccines containing current strains of this virus in each season are recommended. Vaccination with live tuberculosis vaccines (BCG) as well as measles, rubella, mumps, chickenpox/*herpes zoster*, *poliomyelitis* (Sabin and Koprowski vaccine), and yellow fever should be avoided in patients with CLL. Vaccination should not be administered less than two weeks before or during chemoimmunotherapy, or up to six months

**Table 10.** Vaccinations recommended in patients with chronic lymphocytic leukemia (CLL)

Type of vaccine	Method of administration
13-valent conjugate vaccine against <i>Streptococcus pneumoniae</i> (PCV13): only preparation for adults registered in Poland is Prevenar 13®	Vaccination should be performed as soon as diagnosis of CLL is made. PCV13 vaccine (Prevenar 13®) is administered in a single dose, intramuscularly (i.m.) into deltoid muscle. Currently, there is no data on need to repeat PCV13 vaccination
Vaccine against <i>Hemophilus influenzae</i> type B (HiB)	Vaccine against HiB is administered in a single dose, intramuscularly (i.m.) into deltoid muscle or subcutaneously (s.c.). There is currently no data on need for repeated vaccination
Polysaccharide vaccine against <i>Streptococcus pneumoniae</i> (PPSV23): only Pneumovax 23® is available in Poland	Not earlier than two months after PCV13; PPSV23 should be administered i.m. into deltoid muscle or subcutaneously s.c. Booster dose should be administered after 3–5 years, earlier administration may be considered depending on response to vaccine (it is not in line with SmPC); monitoring of antibody levels is advisable
Flu vaccine Multivalent inactivated vaccines against strains recommended each year by WHO for vaccine production These products are available in Poland: • Influvac® — inactivated sub-unit vaccine containing influenza virus surface antigens • Vaxigrip® — inactivated split vaccine with split influenza virion as an antigen • IDflu® — inactivated split vaccine with split influenza virion as an antigen	Intramuscularly into deltoid muscle or subcutaneously s.c., vaccination should be repeated annually before flu season (preferably in September) in patients with secondary immunodeficiency (especially severe hypogammaglobulinemia < 5 g/L) and poor response to vaccination (if a titer of specific antibodies against influenza antigens is not doubled, revaccination after one month may be considered)
Vaccine against HBV	Primary vaccination according to this schedule: 0; 1; 6 months in previously unvaccinated patients, preferably straight after diagnosis In patients undergoing immunosuppressive therapy, it is recommended to maintain antibody levels ≥ 100 IU/L. Antibody control is performed every six months; when concentration drops below < 100 IU/L, a double dose of vaccine should be administered. In patients with profound immunodeficiency (hypogammaglobulinemia IgG requiring IVIG/SCIG supplementation), when concentration of HBs antibodies is < 10 IU/L after primary immunization, it is recommended to administer another 1–3 doses of vaccine. If antibody concentration is still < 10 IU/L, no further vaccinations are performed
SARS-CoV-2 vaccine	It is recommended to administer one or two doses of vaccine, depending on preparation and manufacturer's recommendations

\*According to authors, in patients with blood diseases, it is better to use sub-unit vaccines containing surface subunits (hemagglutinin and influenza virus neuraminidase). In our practice, after administration of split vaccines containing split virion in patients with secondary immunodeficiency, more side effects were observed; SmPC — summary of product characteristics; WHO — World Health Organization; HBV — hepatitis B virus; IVIG/SCIG — intravenous immunoglobulin/subcutaneous immunoglobulin; SARS-CoV-2 — severe acute respiratory syndrome-related coronavirus 2

after the completion of treatment. Preventive vaccinations are also not administered during serious infections and acute feverish diseases. Mild infections (common colds) should not be a reason to postpone vaccination. Table 10 sets out the recommended vaccinations in CLL patients and their routes of administration.

### **Recommendations for vaccination against SARS-CoV-2 in patients with CLL**

Many questions about SARS-CoV-2 vaccination in patients with CLL remain unanswered, because cancer patients were not included in clinical trials. Currently, one absolute contraindication to vaccine administration is hypersensitivity to the active substance or to any of the excipients in the

vaccine preparation. Vaccination decisions should be made on a case-by-case basis in people with a history of severe allergic reactions. Considering the risk of serious complications in the course of COVID-19 in cancer patients, and the good safety profile of vaccines, according to experts from international scientific societies (EHA, ASH, NCCN, ESMO), vaccination against SARS-CoV-2 is recommended in patients with cancers, including chronic lymphocytic leukemia. Antineoplastic treatment is not a contraindication to vaccination: the challenge is to obtain an effective protective response to vaccination in CLL patients, especially patients undergoing immunochemotherapy with anti-CD20 antibodies, treatment with BTK inhibitors, or high doses of glucocorticosteroids.

The protective effect of the vaccine will depend on the degree of immunosuppression associated with the disease and/or treatment of the neoplastic disease. People with CLL should be vaccinated as soon as possible because they are more likely to be hospitalized or to die from severe COVID-19 than the general population. This also applies to patients several years after the completion of oncological treatment [156].

### Treatment of infections

Treatment of infections in patients with CLL depends not only on the type of etiopathogenetic factor, but also on the patient's general condition and risk factors for the development of life-threatening infectious complications, such as hypogammaglobulinemia (including IgG subclass deficiency) and neutropenia [132]. In many countries, antibiotic prophylaxis is used in patients with CLL, despite a lack of evidence of its effectiveness. Especially in patients with bronchiectasis, prophylactic administration of azithromycin at a dose of 250 mg three times a week should be considered [130]. Patients at no risk of sepsis with absolute neutrophil counts above 0.5 G/L may be treated with narrower-range antibiotics targeting the most likely pathogen previously identified in culture [133]. *Herpes simplex* and *herpes zoster* are common in patients with advanced CLL and hinder the use of antileukemic therapies. The course of the infection is usually mild, and oral antiviral drugs are sufficient. If CMV antigenemia is diagnosed in patients treated with alemtuzumab, antiviral therapy should be initiated with gancyclovir 5 mg/kg i.v. twice daily for at least two weeks or valgancyclovir 900 mg twice daily. In patients who are refractory to this treatment, the use of foscarnet or cidofovir is indicated.

### References

1. Swerdlow SH, Campo E, Pileri SA, et al. The 2016 revision of the World Health Organization classification of lymphoid neoplasms. *Blood*. 2016; 127(20): 2375–2390, doi: [10.1182/blood-2016-01-643569](https://doi.org/10.1182/blood-2016-01-643569), indexed in Pubmed: 26980727.
2. Cancer Stat Facts: NHL — Chronic Lymphocytic Leukemia/Small Lymphocytic Lymphoma (CLL/SLL). <https://seer.cancer.gov/stat-facts/html/clsll.html> (April 23, 2021).
3. Hallek M. Chronic lymphocytic leukemia: 2020 update on diagnosis, risk stratification and treatment. *Am J Hematol*. 2019; 94(11): 1266–1287, doi: [10.1002/ajh.25595](https://doi.org/10.1002/ajh.25595), indexed in Pubmed: 31364186.
4. Goldin LR, Slager SL, Caporaso NE. Familial chronic lymphocytic leukemia. *Curr Opin Hematol*. 2010; 17(4): 350–355, doi: [10.1097/MOH.0b013e328338cd99](https://doi.org/10.1097/MOH.0b013e328338cd99), indexed in Pubmed: 20389242.
5. Sud A, Chattopadhyay S, Thomsen H, et al. Analysis of 153 115 patients with hematological malignancies refines the spectrum of familial risk. *Blood*. 2019; 134(12): 960–969, doi: [10.1182/blood.2019001362](https://doi.org/10.1182/blood.2019001362), indexed in Pubmed: 31395603.
6. Robak T. Second malignancies and Richter's syndrome in patients with chronic lymphocytic leukemia. *Hematology*. 2004; 9(5–6): 387–400, doi: [10.1080/10245330400018599](https://doi.org/10.1080/10245330400018599), indexed in Pubmed: 15763979.
7. Hallek M, Cheson BD, Catovsky D, et al. iwCLL guidelines for diagnosis, indications for treatment, response assessment, and supportive management of CLL. *Blood*. 2018; 131(25): 2745–2760, doi: [10.1182/blood-2017-09-806398](https://doi.org/10.1182/blood-2017-09-806398), indexed in Pubmed: 29540348.
8. Eichhorst B, Robak T, Montserrat E, et al. ESMO Guidelines Committee. Chronic lymphocytic leukaemia: ESMO Clinical Practice Guidelines for diagnosis, treatment and follow-up. *Ann Oncol*. 2021; 32(1): 23–33, doi: [10.1016/j.annonc.2020.09.019](https://doi.org/10.1016/j.annonc.2020.09.019), indexed in Pubmed: 33091559.
9. Rawstron AC, Bennett FL, O'Connor SJM, et al. Monoclonal B-cell lymphocytosis and chronic lymphocytic leukemia. *N Engl J Med*. 2008; 359(6): 575–583, doi: [10.1056/NEJMoa075290](https://doi.org/10.1056/NEJMoa075290), indexed in Pubmed: 18687638.
10. Rai KR, Sawitsky A, Cronkite EP, et al. Clinical staging of chronic lymphocytic leukemia. *Blood*. 1975; 46(2): 219–234, indexed in Pubmed: 1139039.
11. Binet JL, Auquier A, Dighiero G, et al. A new prognostic classification of chronic lymphocytic leukemia derived from a multivariate survival analysis. *Cancer*. 1981; 48(1): 198–206, doi: [10.1002/1097-0142\(19810701\)48:1<198::aid-cnrcr2820480131>3.0.co;2-v](https://doi.org/10.1002/1097-0142(19810701)48:1<198::aid-cnrcr2820480131>3.0.co;2-v), indexed in Pubmed: 7237385.
12. Rai KR. A critical analysis of staging in CLL. In: Gale RP, Rai KR, ed. *Chronic lymphocytic leukemia: recent progress and future directions*. Liss, New York 1987: 253–264.
13. Döhner H, Stilgenbauer S, Benner A, et al. Genomic aberrations and survival in chronic lymphocytic leukemia. *N Engl J Med*. 2000; 343(26): 1910–1916, doi: [10.1056/NEJM200012283432602](https://doi.org/10.1056/NEJM200012283432602), indexed in Pubmed: 11136261.
14. Zenz T, Eichhorst B, Busch R, et al. TP53 mutation and survival in chronic lymphocytic leukemia. *J Clin Oncol*. 2010; 28(29): 4473–4479, doi: [10.1200/JCO.2009.27.8762](https://doi.org/10.1200/JCO.2009.27.8762), indexed in Pubmed: 20697090.
15. Hallek M, Fischer K, Fingerle-Rowson G, et al. International Group of Investigators, German Chronic Lymphocytic Leukaemia Study Group. Addition of rituximab to fludarabine and cyclophosphamide in patients with chronic lymphocytic leukaemia: a randomised, open-label, phase 3 trial. *Lancet*. 2010; 376(9747): 1164–1174, doi: [10.1016/S0140-6736\(10\)61381-5](https://doi.org/10.1016/S0140-6736(10)61381-5), indexed in Pubmed: 20888994.
16. O'Brien S, Furman RR, Coutre S, et al. Single-agent ibrutinib in treatment-naïve and relapsed/refractory chronic lymphocytic leukemia: a 5-year experience. *Blood*. 2018; 131(17): 1910–1919, doi: [10.1182/blood-2017-10-810044](https://doi.org/10.1182/blood-2017-10-810044), indexed in Pubmed: 29437592.
17. Jones J, Mato A, Coutre S, et al. Evaluation of 230 patients with relapsed/refractory deletion 17p chronic lymphocytic leukaemia treated with ibrutinib from 3 clinical trials. *Br J Haematol*. 2018; 182(4): 504–512, doi: [10.1111/bjh.15421](https://doi.org/10.1111/bjh.15421), indexed in Pubmed: 29873072.
18. Stilgenbauer S, Eichhorst B, Schetelig J, et al. Venetoclax for patients with chronic lymphocytic leukemia with 17p deletion: results from the full population of a phase II pivotal trial. *J Clin Oncol*. 2018; 36(19): 1973–1980, doi: [10.1200/JCO.2017.76.6840](https://doi.org/10.1200/JCO.2017.76.6840), indexed in Pubmed: 29715056.



19. Fischer K, Al-Sawaf O, Bahlo J, et al. Venetoclax and obinutuzumab in patients with CLL and coexisting conditions. *N Engl J Med.* 2019; 380(23): 2225–2236, doi: [10.1056/NEJMoa1815281](https://doi.org/10.1056/NEJMoa1815281), indexed in Pubmed: [31166681](https://pubmed.ncbi.nlm.nih.gov/31166681/).
20. Hamblin TJ, Davis Z, Gardiner A, et al. Unmutated Ig V(H) genes are associated with a more aggressive form of chronic lymphocytic leukemia. *Blood.* 1999; 94(6): 1848–1854, indexed in Pubmed: [10477713](https://pubmed.ncbi.nlm.nih.gov/10477713/).
21. Lin K, Sherrington PD, Dennis M, et al. Relationship between p53 dysfunction, CD38 expression, and IgV(H) mutation in chronic lymphocytic leukemia. *Blood.* 2002; 100(4): 1404–1409, doi: [10.1182/blood-2001-11-0066](https://doi.org/10.1182/blood-2001-11-0066), indexed in Pubmed: [12149224](https://pubmed.ncbi.nlm.nih.gov/12149224/).
22. Stilgenbauer S, Bullinger L, Lichter P, et al. German CLL Study Group (GCLLSG). Genetic and chronic lymphocytic leukemia: genomic aberrations and V(H) gene mutation status in pathogenesis and clinical course. *Leukemia.* 2002; 16(6): 993–1007, doi: [10.1038/sj.leu.2402537](https://doi.org/10.1038/sj.leu.2402537), indexed in Pubmed: [12040431](https://pubmed.ncbi.nlm.nih.gov/12040431/).
23. Kröber A, Bloehdorn J, Hafner S, et al. Additional genetic high-risk features such as 11q deletion, 17p deletion, and V3-21 usage characterize discordance of ZAP-70 and VH mutation status in chronic lymphocytic leukemia. *J Clin Oncol.* 2006; 24(6): 969–975, doi: [10.1200/JCO.2005.03.7184](https://doi.org/10.1200/JCO.2005.03.7184), indexed in Pubmed: [16418492](https://pubmed.ncbi.nlm.nih.gov/16418492/).
24. Fischer K, Bahlo J, Fink AM, et al. Long-term remissions after FCR chemoimmunotherapy in previously untreated patients with CLL: updated results of the CLL8 trial. *Blood.* 2016; 127(2): 208–215, doi: [10.1182/blood-2015-06-651125](https://doi.org/10.1182/blood-2015-06-651125), indexed in Pubmed: [26486789](https://pubmed.ncbi.nlm.nih.gov/26486789/).
25. Burger JA, Tedeschi A, Barr PM, et al. RESONATE-2 Investigators. Ibrutinib as initial therapy for patients with chronic lymphocytic leukemia. *N Engl J Med.* 2015; 373(25): 2425–2437, doi: [10.1056/NEJMoa1509388](https://doi.org/10.1056/NEJMoa1509388), indexed in Pubmed: [26639149](https://pubmed.ncbi.nlm.nih.gov/26639149/).
26. Shanafelt TD, Wang XV, Kay NE, et al. Ibrutinib-rituximab or chemoimmunotherapy for chronic lymphocytic leukemia. *N Engl J Med.* 2019; 381(5): 432–443, doi: [10.1056/NEJMoa1817073](https://doi.org/10.1056/NEJMoa1817073), indexed in Pubmed: [31365801](https://pubmed.ncbi.nlm.nih.gov/31365801/).
27. Woyach JA, Ruppert AS, Heerema NA, et al. Ibrutinib regimens versus chemoimmunotherapy in older patients with untreated CLL. *N Engl J Med.* 2018; 379(26): 2517–2528, doi: [10.1056/NEJMoa1812836](https://doi.org/10.1056/NEJMoa1812836), indexed in Pubmed: [30501481](https://pubmed.ncbi.nlm.nih.gov/30501481/).
28. Moreno C, Greil R, Demirkan F, et al. Ibrutinib plus obinutuzumab versus chlorambucil plus obinutuzumab in first-line treatment of chronic lymphocytic leukaemia (iLLUMINATE): a multicentre, randomised, open-label, phase 3 trial. *Lancet Oncol.* 2019; 20(1): 43–56, doi: [10.1016/S1470-2045\(18\)30788-5](https://doi.org/10.1016/S1470-2045(18)30788-5), indexed in Pubmed: [30522969](https://pubmed.ncbi.nlm.nih.gov/30522969/).
29. Ghia P, Rawstron A. Minimal residual disease analysis in chronic lymphocytic leukemia: a way for achieving more personalized treatments. *Leukemia.* 2018; 32(6): 1307–1316, doi: [10.1038/s41375-018-0109-x](https://doi.org/10.1038/s41375-018-0109-x), indexed in Pubmed: [29700386](https://pubmed.ncbi.nlm.nih.gov/29700386/).
30. Böttcher S, Ritgen M, Fischer K, et al. Minimal residual disease quantification is an independent predictor of progression-free and overall survival in chronic lymphocytic leukemia: a multivariate analysis from the randomized GCLLSG CLL8 trial. *J Clin Oncol.* 2012; 30(9): 980–988, doi: [10.1200/JCO.2011.36.9348](https://doi.org/10.1200/JCO.2011.36.9348), indexed in Pubmed: [22331940](https://pubmed.ncbi.nlm.nih.gov/22331940/).
31. Kwok M, Rawstron AC, Varghese A, et al. Minimal residual disease is an independent predictor for 10-year survival in CLL. *Blood.* 2016; 128(24): 2770–2773, doi: [10.1182/blood-2016-05-714162](https://doi.org/10.1182/blood-2016-05-714162), indexed in Pubmed: [27697770](https://pubmed.ncbi.nlm.nih.gov/27697770/).
32. Seymour JF, Kipps TJ, Eichhorst B, et al. Venetoclax-rituximab in relapsed or refractory chronic lymphocytic leukemia. *N Engl J Med.* 2018; 378(12): 1107–1120, doi: [10.1056/NEJMoa1713976](https://doi.org/10.1056/NEJMoa1713976), indexed in Pubmed: [29562156](https://pubmed.ncbi.nlm.nih.gov/29562156/).
33. Kater AP, Kipps T, Eichhorst B, et al. Five-year analysis of Murano study demonstrates enduring undetectable minimal residual disease (uMRD) in a subset of relapsed/refractory chronic lymphocytic leukemia (R/R CLL) patients (pts) following fixed-duration venetoclax-rituximab (VenR) therapy (tx). *Blood.* 2020; 136(Suppl 1): 19–21, doi: [10.1182/blood-2020-136109](https://doi.org/10.1182/blood-2020-136109).
34. Catovsky D, Else M, Richards S. Chlorambucil — still not bad: a reappraisal. *Clin Lymphoma Myeloma Leuk.* 2011; 11(Suppl 1): S2–S6, doi: [10.1016/j.clml.2011.02.006](https://doi.org/10.1016/j.clml.2011.02.006).
35. Robak T, Blonski JZ, Jamrozik K, et al. A randomized, multicenter study (PALG CLL4/ML 21283) of maintenance treatment with rituximab versus observation after induction treatment with rituximab, cladribine, and cyclophosphamide (RCC) regimen in patients with progressive chronic lymphocytic leukemia: interim analysis. *Blood.* 2013; 122(21): 1640, doi: [10.1182/blood.v122.21.1640.1640](https://doi.org/10.1182/blood.v122.21.1640.1640).
36. Dearden C, Wade R, Else M, et al. UK National Cancer Research Institute (NCRI), Haematological Oncology Clinical Studies Group, NCRI CLL Working Group. The prognostic significance of a positive direct antiglobulin test in chronic lymphocytic leukemia: a beneficial effect of the combination of fludarabine and cyclophosphamide on the incidence of hemolytic anemia. *Blood.* 2008; 111(4): 1820–1826, doi: [10.1182/blood-2007-07-101303](https://doi.org/10.1182/blood-2007-07-101303), indexed in Pubmed: [18055869](https://pubmed.ncbi.nlm.nih.gov/18055869/).
37. Aapro MS, Bohlius J, Cameron DA, et al. European Organisation for Research and Treatment of Cancer. 2010 update of EORTC guidelines for the use of granulocyte-colony stimulating factor to reduce the incidence of chemotherapy-induced febrile neutropenia in adult patients with lymphoproliferative disorders and solid tumours. *Eur J Cancer.* 2011; 47(1): 8–32, doi: [10.1016/j.ejca.2010.10.013](https://doi.org/10.1016/j.ejca.2010.10.013), indexed in Pubmed: [21095116](https://pubmed.ncbi.nlm.nih.gov/21095116/).
38. Lukenbill J, Kalaycio M. Fludarabine: a review of the clear benefits and potential harms. *Leuk Res.* 2013; 37(9): 986–994, doi: [10.1016/j.leukres.2013.05.004](https://doi.org/10.1016/j.leukres.2013.05.004), indexed in Pubmed: [23787174](https://pubmed.ncbi.nlm.nih.gov/23787174/).
39. Robak T, Błoński J, Skotnicki AB, et al. Rituximab, cladribine, and cyclophosphamide (RCC) induction with rituximab maintenance in chronic lymphocytic leukemia: PALG-CLL4 (ML21283) trial. *Eur J Haematol.* 2018; 100(5): 465–474, doi: [10.1111/ejh.13042](https://doi.org/10.1111/ejh.13042), indexed in Pubmed: [29427355](https://pubmed.ncbi.nlm.nih.gov/29427355/).
40. Robak T, Jamrozik K, Gora-Tybor J, et al. Comparison of cladribine plus cyclophosphamide with fludarabine plus cyclophosphamide as first-line therapy for chronic lymphocytic leukemia: a phase III randomized study by the Polish Adult Leukemia Group (PALG-CLL3 Study). *J Clin Oncol.* 2010; 28(11): 1863–1869, doi: [10.1200/JCO.2009.25.9630](https://doi.org/10.1200/JCO.2009.25.9630), indexed in Pubmed: [20212251](https://pubmed.ncbi.nlm.nih.gov/20212251/).
41. Robak T, Dmoszynska A, Solal-Céligny P, et al. Rituximab plus fludarabine and cyclophosphamide prolongs progression-free survival compared with fludarabine and cyclophosphamide alone in previously treated chronic lymphocytic leukemia. *J Clin Oncol.* 2010; 28(10): 1756–1765, doi: [10.1200/JCO.2009.26.4556](https://doi.org/10.1200/JCO.2009.26.4556), indexed in Pubmed: [20194844](https://pubmed.ncbi.nlm.nih.gov/20194844/).
42. Robak T, Smolewski P, Cebula B, et al. Rituximab combined with cladribine or with cladribine and cyclophosphamide in heavily pretreated patients with indolent lymphoproliferative disorders and mantle cell lymphoma. *Cancer.* 2006; 107(7): 1542–1550, doi: [10.1002/cncr.22196](https://doi.org/10.1002/cncr.22196), indexed in Pubmed: [16948126](https://pubmed.ncbi.nlm.nih.gov/16948126/).
43. Fisher K, Kramer P, Busch R, et al. German CLL Study Group. Bendamustine combined with rituximab in patients with relapsed

- and/or refractory chronic lymphocytic leukemia: a multicenter phase II trial of the German Chronic Lymphocytic Leukemia Study Group. *J Clin Oncol.* 2011; 29(26): 3559–3566, doi: [10.1200/JCO.2010.33.8061](https://doi.org/10.1200/JCO.2010.33.8061), indexed in Pubmed: [21844497](https://pubmed.ncbi.nlm.nih.gov/21844497/).
44. Fischer K, Cramer P, Busch R, et al. Bendamustine in combination with rituximab for previously untreated patients with chronic lymphocytic leukemia: a multicenter phase II trial of the German Chronic Lymphocytic Leukemia Study Group. *J Clin Oncol.* 2012; 30(26): 3209–3216, doi: [10.1200/JCO.2011.39.2688](https://doi.org/10.1200/JCO.2011.39.2688), indexed in Pubmed: [22869884](https://pubmed.ncbi.nlm.nih.gov/22869884/).
  45. Eichhorst B, Fink AM, Bahlo J, et al. international group of investigators, German CLL Study Group (GCLLSG). First-line chemoimmunotherapy with bendamustine and rituximab versus fludarabine, cyclophosphamide, and rituximab in patients with advanced chronic lymphocytic leukaemia (CLL10): an international, open-label, randomised, phase 3, non-inferiority trial. *Lancet Oncol.* 2016; 17(7): 928–942, doi: [10.1016/S1470-2045\(16\)30051-1](https://doi.org/10.1016/S1470-2045(16)30051-1), indexed in Pubmed: [27216274](https://pubmed.ncbi.nlm.nih.gov/27216274/).
  46. Goede V, Fischer K, Busch R, et al. Obinutuzumab plus chlorambucil in patients with CLL and coexisting conditions. *N Engl J Med.* 2014; 370(12): 1101–1110, doi: [10.1056/NEJMoa1313984](https://doi.org/10.1056/NEJMoa1313984), indexed in Pubmed: [24401022](https://pubmed.ncbi.nlm.nih.gov/24401022/).
  47. Goede V, Fischer K, Engelke A, et al. Obinutuzumab as frontline treatment of chronic lymphocytic leukemia: updated results of the CLL11 study. *Leukemia.* 2015; 29(7): 1602–1604, doi: [10.1038/leu.2015.14](https://doi.org/10.1038/leu.2015.14), indexed in Pubmed: [25634683](https://pubmed.ncbi.nlm.nih.gov/25634683/).
  48. Goede V, Fischer K, Dyer M, et al. Overall survival benefit of obinutuzumab over rituximab when combined with chlorambucil in patients with chronic lymphocytic leukemia and comorbidities: final survival analysis of the CLL11 study Study EHA Congress, 2018. Abstract S151.
  49. Hillmen P, Robak T, Janssens A, et al. Chlorambucil plus ofatumumab versus chlorambucil alone in previously untreated patients with chronic lymphocytic leukaemia (COMPLEMENT 1): a randomised, multicentre, open-label phase 3 trial. *Lancet.* 2015; 385(9980): 1873–1883, doi: [10.1016/s0140-6736\(15\)60027-7](https://doi.org/10.1016/s0140-6736(15)60027-7).
  50. Byrd JC, Furman RR, Coutre SE, et al. Targeting BTK with ibrutinib in relapsed chronic lymphocytic leukemia. *N Engl J Med.* 2013; 369(1): 32–42, doi: [10.1056/NEJMoa1215637](https://doi.org/10.1056/NEJMoa1215637), indexed in Pubmed: [23782158](https://pubmed.ncbi.nlm.nih.gov/23782158/).
  51. Byrd JC, Brown JR, O'Brien S, et al. RESONATE Investigators. Ibrutinib versus ofatumumab in previously treated chronic lymphoid leukemia. *N Engl J Med.* 2014; 371(3): 213–223, doi: [10.1056/NEJMoa1400376](https://doi.org/10.1056/NEJMoa1400376), indexed in Pubmed: [24881631](https://pubmed.ncbi.nlm.nih.gov/24881631/).
  52. Byrd JC, Furman RR, Coutre SE, et al. Ibrutinib treatment for first-line and relapsed/refractory chronic lymphocytic leukemia: final analysis of the pivotal phase Ib/II PCYC-1102 study. *Clin Cancer Res.* 2020; 26(15): 3918–3927, doi: [10.1158/1078-0432.CCR-19-2856](https://doi.org/10.1158/1078-0432.CCR-19-2856), indexed in Pubmed: [32209572](https://pubmed.ncbi.nlm.nih.gov/32209572/).
  53. Munir T, Brown JR, O'Brien S, et al. Final analysis from RESONATE: up to six years of follow-up on ibrutinib in patients with previously treated chronic lymphocytic leukemia or small lymphocytic lymphoma. *Am J Hematol.* 2019; 94(12): 1353–1363, doi: [10.1002/ajh.25638](https://doi.org/10.1002/ajh.25638), indexed in Pubmed: [31512258](https://pubmed.ncbi.nlm.nih.gov/31512258/).
  54. Lin VS, Lew TE, Handunnetti SM, et al. BTK inhibitor therapy is effective in patients with CLL resistant to venetoclax. *Blood.* 2020; 135(25): 2266–2270, doi: [10.1182/blood.2020004782](https://doi.org/10.1182/blood.2020004782), indexed in Pubmed: [32244251](https://pubmed.ncbi.nlm.nih.gov/32244251/).
  55. Burger JA, Barr PM, Robak T, et al. Long-term efficacy and safety of first-line ibrutinib treatment for patients with CLL/SLL: 5 years of follow-up from the phase 3 RESONATE-2 study. *Leukemia.* 2020; 34(3): 787–798, doi: [10.1038/s41375-019-0602-x](https://doi.org/10.1038/s41375-019-0602-x), indexed in Pubmed: [31628428](https://pubmed.ncbi.nlm.nih.gov/31628428/).
  56. Ghia P, Pluta A, Wach M, et al. ASCEND: phase III, randomized trial of acalabrutinib versus idelalisib plus rituximab or bendamustine plus rituximab in relapsed or refractory chronic lymphocytic leukemia. *J Clin Oncol.* 2020; 38(25): 2849–2861, doi: [10.1200/JCO.19.03355](https://doi.org/10.1200/JCO.19.03355), indexed in Pubmed: [32459600](https://pubmed.ncbi.nlm.nih.gov/32459600/).
  57. Sharman JP, Egyed M, Jurczak W, et al. Acalabrutinib with or without obinutuzumab versus chlorambucil and obinutuzumab for treatment-naive chronic lymphocytic leukaemia (ELEVATE TN): a randomised, controlled, phase 3 trial. *Lancet.* 2020; 395(10232): 1278–1291, doi: [10.1016/S0140-6736\(20\)30262-2](https://doi.org/10.1016/S0140-6736(20)30262-2), indexed in Pubmed: [32305093](https://pubmed.ncbi.nlm.nih.gov/32305093/).
  58. Furman RR, Sharman JP, Coutre SE, et al. Idelalisib and rituximab in relapsed chronic lymphocytic leukemia. *N Engl J Med.* 2014; 370: 997–1007, doi: [10.1056/nejmoa1315226](https://doi.org/10.1056/nejmoa1315226).
  59. Zinzani PL, Rambaldi A, Gaidano G, et al. Infection control in patients treated for chronic lymphocytic leukemia with ibrutinib or idelalisib: recommendations from Italian society of hematology. *Leuk Res.* 2019; 81: 88–94, doi: [10.1016/j.leukres.2019.04.016](https://doi.org/10.1016/j.leukres.2019.04.016), indexed in Pubmed: [31055248](https://pubmed.ncbi.nlm.nih.gov/31055248/).
  60. Flinn IW, Hillmen P, Montillo M, et al. The phase 3 DUO trial: duvelisib vs ofatumumab in relapsed and refractory CLL/SLL. *Blood.* 2018; 132(23): 2446–2455, doi: [10.1182/blood-2018-05-850461](https://doi.org/10.1182/blood-2018-05-850461), indexed in Pubmed: [30287523](https://pubmed.ncbi.nlm.nih.gov/30287523/).
  61. Roberts AW, Davids MS, Pagel JM, et al. Targeting BCL2 with venetoclax in relapsed chronic lymphocytic leukemia. *N Engl J Med.* 2016; 374(4): 311–322, doi: [10.1056/NEJMoa1513257](https://doi.org/10.1056/NEJMoa1513257), indexed in Pubmed: [26639348](https://pubmed.ncbi.nlm.nih.gov/26639348/).
  62. Stilgenbauer S, Eichhorst B, Schetelig J, et al. Venetoclax for patients with chronic lymphocytic leukemia with 17p deletion: results from the full population of a phase II pivotal trial. *J Clin Oncol.* 2018; 36(19): 1973–1980, doi: [10.1200/JCO.2017.76.6840](https://doi.org/10.1200/JCO.2017.76.6840), indexed in Pubmed: [29715056](https://pubmed.ncbi.nlm.nih.gov/29715056/).
  63. Jones J, Mato A, Wierda W, et al. Venetoclax for chronic lymphocytic leukaemia progressing after ibrutinib: an interim analysis of a multicentre, open-label, phase 2 trial. *Lancet Oncol.* 2018; 19(1): 65–75, doi: [10.1016/s1470-2045\(17\)30909-9](https://doi.org/10.1016/s1470-2045(17)30909-9).
  64. Al-Sawaf O, Zhang C, Robecht S, et al. Clonal dynamics after venetoclax-obinutuzumab therapy: novel insights from the randomized, phase 3 CLL14 trial. *ASH, 2020.* Abstract 127.
  65. Fischer K, Al-Sawaf O, Hallek M. Preventing and monitoring for tumor lysis syndrome and other toxicities of venetoclax during treatment of chronic lymphocytic leukemia. *Hematology Am Soc Hematol Educ Program.* 2020; 2020(1): 357–362, doi: [10.1182/hematology.2020000120](https://doi.org/10.1182/hematology.2020000120), indexed in Pubmed: [33275717](https://pubmed.ncbi.nlm.nih.gov/33275717/).
  66. Dreger P, Schetelig J, Andersen N, et al. European Research Initiative on CLL (ERIC) and the European Society for Blood and Marrow Transplantation (EBMT). Managing high-risk CLL during transition to a new treatment era: stem cell transplantation or novel agents? *Blood.* 2014; 124(26): 3841–3849, doi: [10.1182/blood-2014-07-586826](https://doi.org/10.1182/blood-2014-07-586826), indexed in Pubmed: [25301705](https://pubmed.ncbi.nlm.nih.gov/25301705/).
  67. Dreger P, Michallet M, Bosman P, et al. Ibrutinib for bridging to allogeneic hematopoietic cell transplantation in patients with chronic lymphocytic leukemia or mantle cell lymphoma: a study by the EBMT Chronic Malignancies and Lymphoma Working Parties. *Bone Marrow Transplant.* 2019; 54(1): 44–52, doi: [10.1038/s41409-018-0207-4](https://doi.org/10.1038/s41409-018-0207-4), indexed in Pubmed: [29728701](https://pubmed.ncbi.nlm.nih.gov/29728701/).
  68. Dreger P, Döhner H, Ritgen M, et al. German CLL Study Group. Allogeneic stem cell transplantation provides durable disease

- control in poor-risk chronic lymphocytic leukemia: long-term clinical and MRD results of the German CLL Study Group CLL3X trial. *Blood*. 2010; 116(14): 2438–2447, doi: [10.1182/blood-2010-03-275420](https://doi.org/10.1182/blood-2010-03-275420), indexed in Pubmed: 20595516.
69. Shea T, Johnson J, Westervelt P, et al. Cancer and Leukemia Group B. Reduced-intensity allogeneic transplantation provides high event-free and overall survival in patients with advanced indolent B cell malignancies: CALGB 109901. *Biol Blood Marrow Transplant*. 2011; 17(9): 1395–1403, doi: [10.1016/j.bbmt.2011.01.016](https://doi.org/10.1016/j.bbmt.2011.01.016), indexed in Pubmed: 21296675.
  70. van Gelder M, de Wreede LC, Bornhäuser M, et al. Long-term survival of patients with CLL after allogeneic transplantation: a report from the European Society for Blood and Marrow Transplantation. *Bone Marrow Transplant*. 2017; 52(3): 372–380, doi: [10.1038/bmt.2016.282](https://doi.org/10.1038/bmt.2016.282), indexed in Pubmed: 27941763.
  71. Frey NV, Gill S, Hexner EO, et al. Long-term outcomes from a randomized dose optimization study of chimeric antigen receptor modified t cells in relapsed chronic lymphocytic leukemia. *J Clin Oncol*. 2020; 38(25): 2862–2871, doi: [10.1200/JCO.19.03237](https://doi.org/10.1200/JCO.19.03237), indexed in Pubmed: 32298202.
  72. Linn BS, Linn MW, Gurel L. Cumulative illness rating scale. *J Am Geriatr Soc*. 1968; 16(5): 622–626, doi: [10.1111/j.1532-5415.1968.tb02103.x](https://doi.org/10.1111/j.1532-5415.1968.tb02103.x), indexed in Pubmed: 5646906.
  73. Salvi F, Miller MD, Grilli A, et al. A manual of guidelines to score the modified cumulative illness rating scale and its validation in acute hospitalized elderly patients. *J Am Geriatr Soc*. 2008; 56(10): 1926–1931, doi: [10.1111/j.1532-5415.2008.01935.x](https://doi.org/10.1111/j.1532-5415.2008.01935.x), indexed in Pubmed: 18811613.
  74. Hallek M. Therapy of chronic lymphocytic leukaemia. *Best Pract Res Clin Haematol*. 2010; 23(1): 85–96, doi: [10.1016/j.beha.2009.12.002](https://doi.org/10.1016/j.beha.2009.12.002), indexed in Pubmed: 20620973.
  75. Wierda WG, Byrd JC, Abramson JS, et al. Chronic lymphocytic leukemia/small lymphocytic lymphoma, version 4.2020, NCCN clinical practice guidelines in oncology. *J Natl Compr Canc Netw*. 2020; 18(2): 185–217, doi: [10.6004/jnccn.2020.0006](https://doi.org/10.6004/jnccn.2020.0006), indexed in Pubmed: 32023533.
  76. Cuneo A, Follows G, Rigolin GM, et al. GIMEMA, European Research Initiative on CLL (ERIC) and UK CLL forum. Efficacy of bendamustine and rituximab as first salvage treatment in chronic lymphocytic leukemia and indirect comparison with ibrutinib: a GIMEMA, ERIC and UK CLL FORUM study. *Haematologica*. 2018; 103(7): 1209–1217, doi: [10.3324/haematol.2018.189837](https://doi.org/10.3324/haematol.2018.189837), indexed in Pubmed: 29674504.
  77. Langerbeins P, Busch R, Anheier N, et al. Poor efficacy and tolerability of R-CHOP in relapsed/refractory chronic lymphocytic leukemia and Richter transformation. *Am J Hematol*. 2014; 89(12): E239–E243, doi: [10.1002/ajh.23841](https://doi.org/10.1002/ajh.23841), indexed in Pubmed: 25196783.
  78. Richter MN. Generalized reticular cell sarcoma of lymph nodes associated with lymphatic leukemia. *Am J Pathol*. 1928; 4(4): 285–292.7, indexed in Pubmed: 19969796.
  79. Tsimberidou AM, Keating MJ. Richter syndrome: biology, incidence, and therapeutic strategies. *Cancer*. 2005; 103(2): 216–228, doi: [10.1002/ncr.20773](https://doi.org/10.1002/ncr.20773), indexed in Pubmed: 15578683.
  80. Bockorny B, Codreanu I, Dasanu CA. Hodgkin lymphoma as Richter transformation in chronic lymphocytic leukaemia: a retrospective analysis of world literature. *Br J Haematol*. 2012; 156(1): 50–66, doi: [10.1111/j.1365-2141.2011.08907.x](https://doi.org/10.1111/j.1365-2141.2011.08907.x), indexed in Pubmed: 22017478.
  81. Jamrozik K, Grzybowska-Izydorczyk O, Jesionek-Kupnicka D, et al. Poor prognosis of Hodgkin variant of Richter transformation in chronic lymphocytic leukemia treated with cladribine. *Br J Haematol*. 2012; 158(2): 286–288, doi: [10.1111/j.1365-2141.2012.09127.x](https://doi.org/10.1111/j.1365-2141.2012.09127.x), indexed in Pubmed: 22500554.
  82. Chigrinova E, Rinaldi A, Kwee I, et al. Two main genetic pathways lead to the transformation of chronic lymphocytic leukemia to Richter syndrome. *Blood*. 2013; 122(15): 2673–2682, doi: [10.1182/blood-2013-03-489518](https://doi.org/10.1182/blood-2013-03-489518), indexed in Pubmed: 24004666.
  83. Fabbri G, Khiabani H, Holmes AB, et al. Genetic lesions associated with chronic lymphocytic leukemia transformation to Richter syndrome. *J Exp Med*. 2013; 210(11): 2273–2288, doi: [10.1084/jem.20131448](https://doi.org/10.1084/jem.20131448), indexed in Pubmed: 24127483.
  84. Rossi D, Spina V, Forconi F, et al. Molecular history of Richter syndrome: origin from a cell already present at the time of chronic lymphocytic leukemia diagnosis. *Int J Cancer*. 2012; 130(12): 3006–3010, doi: [10.1002/ijc.26322](https://doi.org/10.1002/ijc.26322), indexed in Pubmed: 21796624.
  85. Tsimberidou AM, O'Brien S, Khouri I, et al. Clinical outcomes and prognostic factors in patients with Richter's syndrome treated with chemotherapy or chemoimmunotherapy with or without stem-cell transplantation. *J Clin Oncol*. 2006; 24(15): 2343–2351, doi: [10.1200/JCO.2005.05.0187](https://doi.org/10.1200/JCO.2005.05.0187), indexed in Pubmed: 16710033.
  86. Papajik T, Mysliveček M, Urbanová R, et al. 2-[18F]fluoro-2-deoxy-D-glucose positron emission tomography/computed tomography examination in patients with chronic lymphocytic leukemia may reveal Richter transformation. *Leuk Lymphoma*. 2014; 55(2): 314–319, doi: [10.3109/10428194.2013.802313](https://doi.org/10.3109/10428194.2013.802313), indexed in Pubmed: 23656196.
  87. Tsimberidou AM, O'Brien SM, Cortes JE, et al. Phase II study of fludarabine, cytarabine (Ara-C), cyclophosphamide, cisplatin and GM-CSF (FACPGM) in patients with Richter's syndrome or refractory lymphoproliferative disorders. *Leuk Lymphoma*. 2002; 43(4): 767–772, doi: [10.1080/10428190290016872](https://doi.org/10.1080/10428190290016872), indexed in Pubmed: 12153163.
  88. Rogers KA, Huang Y, Ruppert AS, et al. A single-institution retrospective cohort study of first-line R-EPOCH chemoimmunotherapy for Richter syndrome demonstrating complex chronic lymphocytic leukaemia karyotype as an adverse prognostic factor. *Br J Haematol*. 2018; 180(2): 259–266, doi: [10.1111/bjh.15035](https://doi.org/10.1111/bjh.15035), indexed in Pubmed: 29193006.
  89. Jain N, Ferrajoli A, Basu S, et al. A phase II trial of nivolumab combined with ibrutinib for patients with Richter transformation [abstract]. *Blood* 2018; 132: 296.
  90. Younes A, Brody J, Carpio C, et al. Safety and activity of ibrutinib in combination with nivolumab in patients with relapsed non-Hodgkin lymphoma or chronic lymphocytic leukaemia: a phase 1/2a study. *Lancet Haematol*. 2019; 6(2): e67–e78, doi: [10.1016/S2352-3026\(18\)30217-5](https://doi.org/10.1016/S2352-3026(18)30217-5), indexed in Pubmed: 30642819.
  91. Ding W, LaPlant BR, Call TG, et al. Pembrolizumab in patients with CLL and Richter transformation or with relapsed CLL. *Blood*. 2017; 129(26): 3419–3427, doi: [10.1182/blood-2017-02-765685](https://doi.org/10.1182/blood-2017-02-765685), indexed in Pubmed: 28424162.
  92. Cwynarski K, van Biezen A, de Wreede L, et al. Autologous and allogeneic stem-cell transplantation for transformed chronic lymphocytic leukemia (Richter's syndrome): a retrospective analysis from the chronic lymphocytic leukemia subcommittee of the chronic leukemia working party and lymphoma working party of the European Group for Blood and Marrow Transplantation. *J Clin Oncol*. 2012; 30(18): 2211–2217, doi: [10.1200/JCO.2011.37.4108](https://doi.org/10.1200/JCO.2011.37.4108), indexed in Pubmed: 22547610.

93. Wang Y, Tschautscher MA, Rabe KG, et al. Clinical characteristics and outcomes of Richter transformation: experience of 204 patients from a single center. *Haematologica*. 2020; 105(3): 765–773, doi: [10.3324/haematol.2019.224121](https://doi.org/10.3324/haematol.2019.224121), indexed in Pubmed: [31197071](https://pubmed.ncbi.nlm.nih.gov/31197071/).
94. Tsimberidou AM, O'Brien S, Kantarjian HM, et al. Hodgkin transformation of chronic lymphocytic leukemia: the M. D. Anderson Cancer Center experience. *Cancer*. 2006; 107(6): 1294–1302, doi: [10.1002/cncr.22121](https://doi.org/10.1002/cncr.22121), indexed in Pubmed: [16902984](https://pubmed.ncbi.nlm.nih.gov/16902984/).
95. Barcellini W, Capalbo S, Agostinelli RM, et al. GIMEMA Chronic Lymphocytic Leukemia Group. Relationship between autoimmune phenomena and disease stage and therapy in B-cell chronic lymphocytic leukemia. *Haematologica*. 2006; 91(12): 1689–1692, indexed in Pubmed: [17145607](https://pubmed.ncbi.nlm.nih.gov/17145607/).
96. Zent CS, Kay N. Autoimmune complications in chronic lymphocytic leukaemia (CLL). *Best Pract Res Clin Haematol*. 2010; 23(1): 47–59, doi: [10.1016/j.beha.2010.01.004](https://doi.org/10.1016/j.beha.2010.01.004).
97. Dearden C, Wade R, Else M, et al. UK National Cancer Research Institute (NCRI), Haematological Oncology Clinical Studies Group, NCRI CLL Working Group. The prognostic significance of a positive direct antiglobulin test in chronic lymphocytic leukemia: a beneficial effect of the combination of fludarabine and cyclophosphamide on the incidence of hemolytic anemia. *Blood*. 2008; 111(4): 1820–1826, doi: [10.1182/blood-2007-07-101303](https://doi.org/10.1182/blood-2007-07-101303), indexed in Pubmed: [18055869](https://pubmed.ncbi.nlm.nih.gov/18055869/).
98. Lewis FB, Schwartz RS, Dameshek W. X-radiation and alkylating agents as possible „trigger” mechanisms in the autoimmune complications of malignant lymphoproliferative disease. *Clin Exp Immunol*. 1966; 1(1): 3–11, indexed in Pubmed: [5953036](https://pubmed.ncbi.nlm.nih.gov/5953036/).
99. Montillo M, Tedeschi A, Leoni P. Recurrence of autoimmune thrombocytopenia after treatment with fludarabine in a patient with chronic lymphocytic leukemia. *Leuk Lymphoma*. 1994; 15(1–2): 187–188, doi: [10.3109/10428199409051696](https://doi.org/10.3109/10428199409051696), indexed in Pubmed: [7858499](https://pubmed.ncbi.nlm.nih.gov/7858499/).
100. Weiss RB, Freiman J, Kweder SL, et al. Hemolytic anemia after fludarabine therapy for chronic lymphocytic leukemia. *J Clin Oncol*. 1998; 16(5): 1885–1889, doi: [10.1200/JCO.1998.16.5.1885](https://doi.org/10.1200/JCO.1998.16.5.1885), indexed in Pubmed: [9586905](https://pubmed.ncbi.nlm.nih.gov/9586905/).
101. Myint H, Coppstone JA, Orchard J, et al. Fludarabine-related autoimmune haemolytic anaemia in patients with chronic lymphocytic leukaemia. *Br J Haematol*. 1995; 91(2): 341–344, doi: [10.1111/j.1365-2141.1995.tb05300.x](https://doi.org/10.1111/j.1365-2141.1995.tb05300.x), indexed in Pubmed: [8547072](https://pubmed.ncbi.nlm.nih.gov/8547072/).
102. Rogers KA, Ruppert AS, Bingman A, et al. Incidence and description of autoimmune cytopenias during treatment with ibrutinib for chronic lymphocytic leukemia. *Leukemia*. 2016; 30(2): 346–350, doi: [10.1038/leu.2015.273](https://doi.org/10.1038/leu.2015.273), indexed in Pubmed: [26442611](https://pubmed.ncbi.nlm.nih.gov/26442611/).
103. Montillo M, O'Brien S, Tedeschi A, et al. Ibrutinib in previously treated chronic lymphocytic leukemia patients with autoimmune cytopenias in the RESONATE study. *Blood Cancer J*. 2017; 7(2): e524, doi: [10.1038/bcj.2017.5](https://doi.org/10.1038/bcj.2017.5), indexed in Pubmed: [28157216](https://pubmed.ncbi.nlm.nih.gov/28157216/).
104. Hampel PJ, Larson MC, Kabat B, et al. Autoimmune cytopenias in patients with chronic lymphocytic leukaemia treated with ibrutinib in routine clinical practice at an academic medical centre. *Br J Haematol*. 2018; 183(3): 421–427, doi: [10.1111/bjh.15545](https://doi.org/10.1111/bjh.15545), indexed in Pubmed: [30117139](https://pubmed.ncbi.nlm.nih.gov/30117139/).
105. Davids MS, Hallek M, Wierda W, et al. Comprehensive safety analysis of venetoclax monotherapy for patients with relapsed/refractory chronic lymphocytic leukemia. *Clin Cancer Res*. 2018; 24(18): 4371–4379, doi: [10.1158/1078-0432.CCR-17-3761](https://doi.org/10.1158/1078-0432.CCR-17-3761), indexed in Pubmed: [29895707](https://pubmed.ncbi.nlm.nih.gov/29895707/).
106. Dearden C. Disease-specific complications of chronic lymphocytic leukemia. *Hematology Am Soc Hematol Educ Program*. 2008; 450–456, doi: [10.1182/asheducation-2008.1.450](https://doi.org/10.1182/asheducation-2008.1.450), indexed in Pubmed: [19074125](https://pubmed.ncbi.nlm.nih.gov/19074125/).
107. Cortes J, O'Brien S, Loscertales J, et al. Cyclosporin A for the treatment of cytopenia associated with chronic lymphocytic leukemia. *Cancer*. 2001; 92(8): 2016–2022, doi: [10.1002/1097-0142\(20011015\)92:8<2016::aid-cncr1539>3.0.co;2-e](https://doi.org/10.1002/1097-0142(20011015)92:8<2016::aid-cncr1539>3.0.co;2-e), indexed in Pubmed: [11596014](https://pubmed.ncbi.nlm.nih.gov/11596014/).
108. D'Arena G, Laurenti L, Capalbo S, et al. Rituximab therapy for chronic lymphocytic leukemia-associated autoimmune hemolytic anemia. *Am J Hematol*. 2006; 81(8): 598–602, doi: [10.1002/ajh.20665](https://doi.org/10.1002/ajh.20665), indexed in Pubmed: [16823816](https://pubmed.ncbi.nlm.nih.gov/16823816/).
109. Bowen DA, Call TG, Shanafelt TD, et al. Treatment of autoimmune cytopenia complicating progressive chronic lymphocytic leukemia/small lymphocytic lymphoma with rituximab, cyclophosphamide, vincristine, and prednisone. *Leuk Lymphoma*. 2010; 51(4): 620–627, doi: [10.3109/10428191003682767](https://doi.org/10.3109/10428191003682767), indexed in Pubmed: [20302386](https://pubmed.ncbi.nlm.nih.gov/20302386/).
110. Kaufman M, Limaye SA, Driscoll N, et al. A combination of rituximab, cyclophosphamide and dexamethasone effectively treats immune cytopenias of chronic lymphocytic leukemia. *Leuk Lymphoma*. 2009; 50(6): 892–899, doi: [10.1080/10428190902887563](https://doi.org/10.1080/10428190902887563), indexed in Pubmed: [19391041](https://pubmed.ncbi.nlm.nih.gov/19391041/).
111. Robak T, Błasińska-Morawiec M, Krykowski E, et al. Autoimmune haemolytic anaemia in patients with chronic lymphocytic leukaemia treated with 2-chlorodeoxyadenosine (cladribine). *Eur J Haematol*. 1997; 58(2): 109–113, doi: [10.1111/j.1600-0609.1997.tb00933.x](https://doi.org/10.1111/j.1600-0609.1997.tb00933.x), indexed in Pubmed: [9111592](https://pubmed.ncbi.nlm.nih.gov/9111592/).
112. Quinquenel A, Willekens C, Dupuis J, et al. Bendamustine and rituximab combination in the management of chronic lymphocytic leukemia-associated autoimmune hemolytic anemia: a multicentric retrospective study of the French CLL intergroup (GCFLLC/MW and GOELAMS). *Am J Hematol*. 2015; 90(3): 204–207, doi: [10.1002/ajh.23909](https://doi.org/10.1002/ajh.23909), indexed in Pubmed: [25428829](https://pubmed.ncbi.nlm.nih.gov/25428829/).
113. Quinquenel A, Godet S, Dartigeas C, et al. Ibrutinib and idelalisib in the management of CLL-associated autoimmune cytopenias: a study from the FILO group. *Am J Hematol*. 2019; 94(7): E183–E185, doi: [10.1002/ajh.25480](https://doi.org/10.1002/ajh.25480), indexed in Pubmed: [30945328](https://pubmed.ncbi.nlm.nih.gov/30945328/).
114. Lacerda MP, Guedes NR, Yamakawa PE, et al. Treatment of refractory autoimmune hemolytic anemia with venetoclax in relapsed chronic lymphocytic leukemia with del(17p). *Ann Hematol*. 2017; 96(9): 1577–1578, doi: [10.1007/s00277-017-3039-1](https://doi.org/10.1007/s00277-017-3039-1), indexed in Pubmed: [28597168](https://pubmed.ncbi.nlm.nih.gov/28597168/).
115. Zent CS, Ding W, Schwager SM, et al. The prognostic significance of cytopenia in chronic lymphocytic leukaemia/small lymphocytic lymphoma. *Br J Haematol*. 2008; 141(5): 615–621, doi: [10.1111/j.1365-2141.2008.07086.x](https://doi.org/10.1111/j.1365-2141.2008.07086.x), indexed in Pubmed: [18373706](https://pubmed.ncbi.nlm.nih.gov/18373706/).
116. Visco C, Ruggeri M, Laura Evangelista M, et al. Impact of immune thrombocytopenia on the clinical course of chronic lymphocytic leukemia. *Blood*. 2008; 111(3): 1110–1116, doi: [10.1182/blood-2007-09-111492](https://doi.org/10.1182/blood-2007-09-111492), indexed in Pubmed: [17986663](https://pubmed.ncbi.nlm.nih.gov/17986663/).
117. Kyasa MJ, Parrish RS, Schichman SA, et al. Autoimmune cytopenia does not predict poor prognosis in chronic lymphocytic leukemia/small lymphocytic lymphoma. *Am J Hematol*. 2003; 74(1): 1–8, doi: [10.1002/ajh.10369](https://doi.org/10.1002/ajh.10369), indexed in Pubmed: [12949883](https://pubmed.ncbi.nlm.nih.gov/12949883/).
118. Hamblin TJ, Oscier DG, Young BJ. Autoimmunity in chronic lymphocytic leukaemia. *J Clin Pathol*. 1986; 39(7): 713–716, doi: [10.1136/jcp.39.7.713](https://doi.org/10.1136/jcp.39.7.713), indexed in Pubmed: [3488334](https://pubmed.ncbi.nlm.nih.gov/3488334/).
119. D'Arena G, Capalbo S, Laurenti L, et al. Chronic lymphocytic leukemia-associated immune thrombocytopenia treated with

- rituximab: a retrospective study of 21 patients. *Eur J Haematol.* 2010; 85(6): 502–507, doi: [10.1111/j.1600-0609.2010.01527.x](https://doi.org/10.1111/j.1600-0609.2010.01527.x), indexed in Pubmed: [20846302](https://pubmed.ncbi.nlm.nih.gov/20846302/).
120. Rossignol J, Michallet AS, Oberic L, et al. Rituximab–cyclophosphamide–dexamethasone combination in the management of autoimmune cytopenias associated with chronic lymphocytic leukemia. *Leukemia.* 2011; 25(3): 473–478, doi: [10.1038/leu.2010.278](https://doi.org/10.1038/leu.2010.278), indexed in Pubmed: [21127498](https://pubmed.ncbi.nlm.nih.gov/21127498/).
  121. Cesana C, Carlo-Stella C, Mangoni L, et al. Response to cyclosporin A and recombinant human erythropoietin in a case of B cell chronic lymphocytic leukemia and pure red cell aplasia. *Leukemia.* 1996; 10(8): 1400–1401, indexed in Pubmed: [8709652](https://pubmed.ncbi.nlm.nih.gov/8709652/).
  122. Koehrer S, Keating MJ, Wierda WG. Eltrombopag, a second-generation thrombopoietin receptor agonist, for chronic lymphocytic leukemia-associated ITP. *Leukemia.* 2010; 24(5): 1096–1098, doi: [10.1038/leu.2010.45](https://doi.org/10.1038/leu.2010.45), indexed in Pubmed: [20339441](https://pubmed.ncbi.nlm.nih.gov/20339441/).
  123. Visco C, Rodeghiero F, Romano A, et al. Eltrombopag for immune thrombocytopenia secondary to chronic lymphoproliferative disorders: a phase 2 multicenter study. *Blood.* 2019; 134(20): 1708–1711, doi: [10.1182/blood.2019001617](https://doi.org/10.1182/blood.2019001617), indexed in Pubmed: [31570488](https://pubmed.ncbi.nlm.nih.gov/31570488/).
  124. Paul S, Jain N, Ferrajoli A, et al. A phase II trial of eltrombopag for patients with chronic lymphocytic leukaemia (CLL) and thrombocytopenia. *Br J Haematol.* 2019; 185(3): 606–608, doi: [10.1111/bjh.15581](https://doi.org/10.1111/bjh.15581), indexed in Pubmed: [30406944](https://pubmed.ncbi.nlm.nih.gov/30406944/).
  125. Chikkappa G, Pasquale D, Zarrabi MH, et al. Cyclosporine and prednisone therapy for pure red cell aplasia in patients with chronic lymphocytic leukemia. *Am J Hematol.* 1992; 41(1): 5–12, doi: [10.1002/ajh.2830410103](https://doi.org/10.1002/ajh.2830410103), indexed in Pubmed: [1503099](https://pubmed.ncbi.nlm.nih.gov/1503099/).
  126. Ghazal H. Successful treatment of pure red cell aplasia with rituximab in patients with chronic lymphocytic leukemia. *Blood.* 2002; 99(3): 1092–1094, doi: [10.1182/blood.v99.3.1092](https://doi.org/10.1182/blood.v99.3.1092), indexed in Pubmed: [11807020](https://pubmed.ncbi.nlm.nih.gov/11807020/).
  127. Abbott BL. Chronic lymphocytic leukemia: recent advances in diagnosis and treatment. *Oncologist.* 2006; 11(1): 21–30, doi: [10.1634/theoncologist.11-1-21](https://doi.org/10.1634/theoncologist.11-1-21), indexed in Pubmed: [16401710](https://pubmed.ncbi.nlm.nih.gov/16401710/).
  128. Oscier D, Dearden C, Eren E, et al. British Committee for Standards in Haematology. Guidelines on the diagnosis, investigation and management of chronic lymphocytic leukaemia. *Br J Haematol.* 2012; 159(5): 541–564, doi: [10.1111/bjh.12067](https://doi.org/10.1111/bjh.12067), indexed in Pubmed: [23057493](https://pubmed.ncbi.nlm.nih.gov/23057493/).
  129. Molica S. Infections in chronic lymphocytic leukemia: risk factors, and impact on survival, and treatment. *Leuk Lymphoma.* 1994; 13(3-4): 203–214, doi: [10.3109/10428199409056283](https://doi.org/10.3109/10428199409056283), indexed in Pubmed: [8049645](https://pubmed.ncbi.nlm.nih.gov/8049645/).
  130. Quinquenel A, Aurran-Schleinitz T, Clavert A, et al. Diagnosis and Treatment of Chronic Lymphocytic Leukemia: Recommendations of the French CLL Study Group (FILO). *Hemasphere.* 2020; 4(5): e473, doi: [10.1097/HS9.0000000000000473](https://doi.org/10.1097/HS9.0000000000000473), indexed in Pubmed: [33062946](https://pubmed.ncbi.nlm.nih.gov/33062946/).
  131. Molteni A, Nosari A, Montillo M, et al. Multiple lines of chemotherapy are the main risk factor for severe infections in patients with chronic lymphocytic leukemia with febrile episodes. *Haematologica.* 2005; 90(8): 1145–1147, indexed in Pubmed: [16079122](https://pubmed.ncbi.nlm.nih.gov/16079122/).
  132. Morrison VA. Management of infectious complications in patients with chronic lymphocytic leukemia. *Hematology.* 2007; 2007(1): 332–338, doi: [10.1182/asheducation-2007.1.332](https://doi.org/10.1182/asheducation-2007.1.332).
  133. Rai KR, Keating MJ. Overview of the complications of chronic lymphocytic leukemia. <https://www.uptodate.com/contents/overview-of-the-complications-of-chronic-lymphocytic-leukemia> (March 30, 2021).
  134. Ye X, Xiao X, Li B, et al. Low humoral immune response and ineffective clearance of SARS-CoV-2 in a COVID-19 patient with CLL during a 69-day follow-up. *Front Oncol.* 2020; 10: 1272, doi: [10.3389/fonc.2020.01272](https://doi.org/10.3389/fonc.2020.01272), indexed in Pubmed: [32719750](https://pubmed.ncbi.nlm.nih.gov/32719750/).
  135. Kos I, Balensiefer B, Roth S, et al. Prolonged course of COVID-19-associated pneumonia in a B-cell depleted patient after rituximab. *Front Oncol.* 2020; 10: 1578, doi: [10.3389/fonc.2020.01578](https://doi.org/10.3389/fonc.2020.01578), indexed in Pubmed: [32984017](https://pubmed.ncbi.nlm.nih.gov/32984017/).
  136. Hammond SP, Chen K, Pandit A, et al. Risk of hepatitis B virus reactivation in patients treated with ibrutinib. *Blood.* 2018; 131(17): 1987–1989, doi: [10.1182/blood-2018-01-826495](https://doi.org/10.1182/blood-2018-01-826495), indexed in Pubmed: [29490923](https://pubmed.ncbi.nlm.nih.gov/29490923/).
  137. Pawłowska M, Flisiak R, Gil L, et al. Prophylaxis of hepatitis B virus (HBV) infection reactivation — recommendations of the Working Group for prevention of HBV reactivation. *Clin Exp Hepatol.* 2019; 5(3): 195–202, doi: [10.5114/ceh.2019.87631](https://doi.org/10.5114/ceh.2019.87631), indexed in Pubmed: [31598555](https://pubmed.ncbi.nlm.nih.gov/31598555/).
  138. Ryan CE, Cheng MP, Issa NC, et al. Pneumocystis jirovecii pneumonia and institutional prophylaxis practices in CLL patients treated with BTK inhibitors. *Blood Adv.* 2020; 4(7): 1458–1463, doi: [10.1182/bloodadvances.2020001678](https://doi.org/10.1182/bloodadvances.2020001678), indexed in Pubmed: [32282880](https://pubmed.ncbi.nlm.nih.gov/32282880/).
  139. Ghez D, Calleja A, Protin C, et al. Early-onset invasive aspergillosis and other fungal infections in patients treated with ibrutinib. *Blood.* 2018; 131(17): 1955–1959, doi: [10.1182/blood-2017-11-818286](https://doi.org/10.1182/blood-2017-11-818286).
  140. Besa EC. Use of intravenous immunoglobulin in chronic lymphocytic leukemia. *Am J Med.* 1984; 76(3A): 209–218, doi: [10.1016/0002-9343\(84\)90344-9](https://doi.org/10.1016/0002-9343(84)90344-9), indexed in Pubmed: [6424454](https://pubmed.ncbi.nlm.nih.gov/6424454/).
  141. Griffiths H, Brennan V, Lea J, et al. Crossover study of immunoglobulin replacement therapy in patients with low-grade B-cell tumors. *Blood.* 1989; 73(2): 366–368, indexed in Pubmed: [2492832](https://pubmed.ncbi.nlm.nih.gov/2492832/).
  142. Wasserman RL, Church JA, Peter HH, et al. IgPro10 in PID Study group. Pharmacokinetics of a new 10% intravenous immunoglobulin in patients receiving replacement therapy for primary immunodeficiency. *Eur J Pharm Sci.* 2009; 37(3–4): 272–278, doi: [10.1016/j.ejps.2009.02.014](https://doi.org/10.1016/j.ejps.2009.02.014), indexed in Pubmed: [19491015](https://pubmed.ncbi.nlm.nih.gov/19491015/).
  143. Lucas M, Hugh-Jones K, Welby A, et al. Immunomodulatory therapy to achieve maximum efficacy: doses, monitoring, compliance, and self-infusion at home. *J Clin Immunol.* 2010; 30(Suppl 1): S84–S89, doi: [10.1007/s10875-010-9400-y](https://doi.org/10.1007/s10875-010-9400-y), indexed in Pubmed: [20387103](https://pubmed.ncbi.nlm.nih.gov/20387103/).
  144. Maarschalk-Ellebroek LJ, Hoepelman IM, Ellebroek PM. Immunoglobulin treatment in primary antibody deficiency. *Int J Antimicrob Agents.* 2011; 37(5): 396–404, doi: [10.1016/j.ijantimicag.2010.11.027](https://doi.org/10.1016/j.ijantimicag.2010.11.027), indexed in Pubmed: [21276714](https://pubmed.ncbi.nlm.nih.gov/21276714/).
  145. Provan D, Chapel HM, Sewell WA, et al. UK Immunoglobulin Expert Working Group. Prescribing intravenous immunoglobulin: summary of Department of Health guidelines. *BMJ.* 2008; 337: a1831, doi: [10.1136/bmj.a1831](https://doi.org/10.1136/bmj.a1831), indexed in Pubmed: [18936060](https://pubmed.ncbi.nlm.nih.gov/18936060/).
  146. Scarfò L, Chatzikonstantinou T, Rigolin GM, et al. COVID-19 severity and mortality in patients with chronic lymphocytic leukemia: a joint study by ERIC, the European Research Initiative on CLL, and CLL Campus. *Leukemia.* 2020; 34(9): 2354–2363, doi: [10.1038/s41375-020-0959-x](https://doi.org/10.1038/s41375-020-0959-x), indexed in Pubmed: [32647324](https://pubmed.ncbi.nlm.nih.gov/32647324/).
  147. Hosoda T, Harada S, Okamoto K, et al. COVID-19 and fatal sepsis caused by hypervirulent klebsiella pneumoniae, Japan, 2020. *Emerg Infect Dis.* 2021; 27(2): 556–559, doi: [10.3201/eid2702.204662](https://doi.org/10.3201/eid2702.204662), indexed in Pubmed: [33320080](https://pubmed.ncbi.nlm.nih.gov/33320080/).
  148. Zhou F, Yu T, Du R, et al. Clinical course and risk factors for mortality of adult inpatients with COVID-19 in Wuhan, China: a retro-

- spective cohort study. *Lancet*. 2020; 395(10229): 1054–1062, doi: [10.1016/S0140-6736\(20\)30566-3](https://doi.org/10.1016/S0140-6736(20)30566-3), indexed in Pubmed: [32171076](https://pubmed.ncbi.nlm.nih.gov/32171076/).
149. Griffiths H, Lea J, Bunch C, et al. Predictors of infection in chronic lymphocytic leukaemia (CLL). *Clin Exp Immunol*. 1992; 89(3): 374–377, doi: [10.1111/j.1365-2249.1992.tb06965.x](https://doi.org/10.1111/j.1365-2249.1992.tb06965.x), indexed in Pubmed: [1516254](https://pubmed.ncbi.nlm.nih.gov/1516254/).
150. Sinisalo M, Aittoniemi J, Käyhty H, et al. Vaccination against infections in chronic lymphocytic leukemia. *Leuk Lymphoma*. 2003; 44(4): 649–652, doi: [10.1080/1042819031000063408](https://doi.org/10.1080/1042819031000063408), indexed in Pubmed: [12769342](https://pubmed.ncbi.nlm.nih.gov/12769342/).
151. Sinisalo M, Vilpo J, Itälä M, et al. Antibody response to 7-valent conjugated pneumococcal vaccine in patients with chronic lymphocytic leukaemia. *Vaccine*. 2007; 26(1): 82–87, doi: [10.1016/j.vaccine.2007.10.053](https://doi.org/10.1016/j.vaccine.2007.10.053), indexed in Pubmed: [18053620](https://pubmed.ncbi.nlm.nih.gov/18053620/).
152. Pollyea DA, Brown JMY, Horning SJ. Utility of influenza vaccination for oncology patients. *J Clin Oncol*. 2010; 28(14): 2481–2490, doi: [10.1200/JCO.2009.26.6908](https://doi.org/10.1200/JCO.2009.26.6908), indexed in Pubmed: [20385981](https://pubmed.ncbi.nlm.nih.gov/20385981/).
153. Hartkamp A, Mulder AH, Rijkers GT, et al. Antibody responses to pneumococcal and haemophilus vaccinations in patients with B-cell chronic lymphocytic leukaemia. *Vaccine*. 2001; 19(13–14): 1671–1677, doi: [10.1016/s0264-410x\(00\)00409-6](https://doi.org/10.1016/s0264-410x(00)00409-6), indexed in Pubmed: [11166890](https://pubmed.ncbi.nlm.nih.gov/11166890/).
154. de Lavallade H, Garland P, Sekine T, et al. Repeated vaccination is required to optimize seroprotection against H1N1 in the immunocompromised host. *Haematologica*. 2011; 96(2): 307–314, doi: [10.3324/haematol.2010.032664](https://doi.org/10.3324/haematol.2010.032664), indexed in Pubmed: [20971824](https://pubmed.ncbi.nlm.nih.gov/20971824/).
155. Yri OE, Torfoss D, Hungnes O, et al. Rituximab blocks protective serologic response to influenza A (H1N1) 2009 vaccination in lymphoma patients during or within 6 months after treatment. *Blood*. 2011; 118(26): 6769–6771, doi: [10.1182/blood-2011-08-372649](https://doi.org/10.1182/blood-2011-08-372649), indexed in Pubmed: [22058114](https://pubmed.ncbi.nlm.nih.gov/22058114/).
156. Garassino MC, Vyas M, de Vries EGE, et al. European Society for Medical Oncology. The ESMO call to action on COVID-19 vaccinations and patients with cancer: Vaccinate. Monitor. Educate. *Ann Oncol*. 2021; 32(5): 579–581, doi: [10.1016/j.annonc.2021.01.068](https://doi.org/10.1016/j.annonc.2021.01.068), indexed in Pubmed: [33582237](https://pubmed.ncbi.nlm.nih.gov/33582237/).